



Split Low-Profile Cooling System
Operation Care Installation Manual

WM-1500SSL WM-1500SSL-LA
WM-2500SSL WM-2500SSL-LA
WM-4500SSL WM-4500SSL-LA
WM-6500SSL WM-6500SSL-LA
WM-8500SSL WM-8500SSL-LA



By *Vinotemp*[®]

www.vinotemp.com

Read and save these instructions

Vinotemp International Corp
732 South Racetrack Road, Henderson, NV 89015
Tel: (800) 777-VINO Fax: (310) 886-3310 Email: info@vinotemp.com

Important Safety Information

WARNING



To avoid the risk of electrical shock, property damage, personal injury, or death:

- The power cord must be plugged into a 3-prong grounding type wall receptacle, grounded in accordance with the National Electrical Code, ANSI/NFPA 70 – latest edition and local codes and ordinances.
- It is the personal responsibility of the consumer to have a proper 3-prong wall receptacle installed by a qualified electrician.
- **DO NOT, UNDER ANY CIRCUMSTANCES, REMOVE THE POWER CORD GROUNDING PRONG.**
- A separate adequately fused and grounded circuit should be available for this appliance.
- Do not remove any grounding wires from individual components while servicing unless the component is to be removed and replaced. It is extremely important to replace all grounding wires when components are replaced.

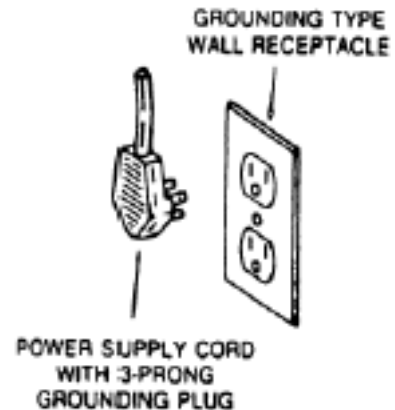

WARNING



ELECTRICAL SHOCK HAZARD

- Disconnect electrical supply from appliance before servicing.
 - Replace all panels before operating.
- Failure to do so could result in death or electrical shock.

Table of Contents

Cellar Construction Guide ----- 3

Features & Specifications ----- 4

Temperature & Humidity ----- 6

Care Guide ----- 10

User' Troubleshooting ----- 11

Installer's Instructions ----- 14

Electrical Wirings ----- 27

Warranty----- 30

Cellar Construction Guide

This is only a guide and shall be considered as the minimum requirements.

All interior walls, ceilings and floors shall have a vapor barrier and a minimum of R13 insulation. All exterior walls and ceiling shall have a vapor barrier and a minimum of R19 insulation. The vapor barrier shall be installed on the warm side of insulation. All joints, door frames, electrical outlets or switches and any pipes or vents that go through the cellar shall be sealed to prevent air and moisture leaking into the cellar. Concrete, rock, and brick are not insulations or vapor barriers. Doors shall be of a minimum size, insulated to at least R13 and tightly sealed with high quality weather stripping. Be sure to seal the bottom of the door and fill gap between the door's frame and wall before installing the cap molding.

In order to maintain 55 °F in the wine cellar, the ambient temperature surrounding the cellar shall not exceed the temperature of the cellar by more than 25 °F. No cellar walls shall receive direct sun or strong wind.

Lighting shall be of low wattage, with a timer to insure lights are not left on when the cellar is not occupied.

The cooling system will not be able to maintain the proper temperature if fresh moisture-laden air is constantly being introduced to the cellar. Symptoms of this condition are; cooling unit runs all the time with only a slight reduction in temperature and/or water overflows from the cooling unit. Because of the temperature difference between the inside and outside, very small cracks can allow large amounts of outside air to enter into the cellar. Please be aware that moisture can pass through solid concrete, paint and wood. Often a newly constructed cellar contains fresh wood, paint, concrete and other building materials. These materials contain large amounts of moisture. When placed into operation in this type of environment, the system will work harder to remove this extra moisture resulting in increased "run" time.

Features and Specifications

- WINE~MATE split low-profile cooling systems WM-1500~8500SSL and WM-1500~8500SSL-LA are designed to provide a cold environment between 50~65 °F with a humidity range within 50~70% RH for a properly insulated wine cellar.
- These temperature and humidity ranges are optimized for long term storage of wine like that in natural caves.
- SSL evaporator units can be installed on the ceiling in a small cabinet or room. The evaporator units provide low profile and whisper quiet operation.
- SSL cooling systems consist of a remote condensing unit and an evaporator unit and they are connected by a liquid line and an insulated suction line.
- SSL condensing units can be located away from the wine cellars up to 75 ft so that noise and compressor vibration are isolated.

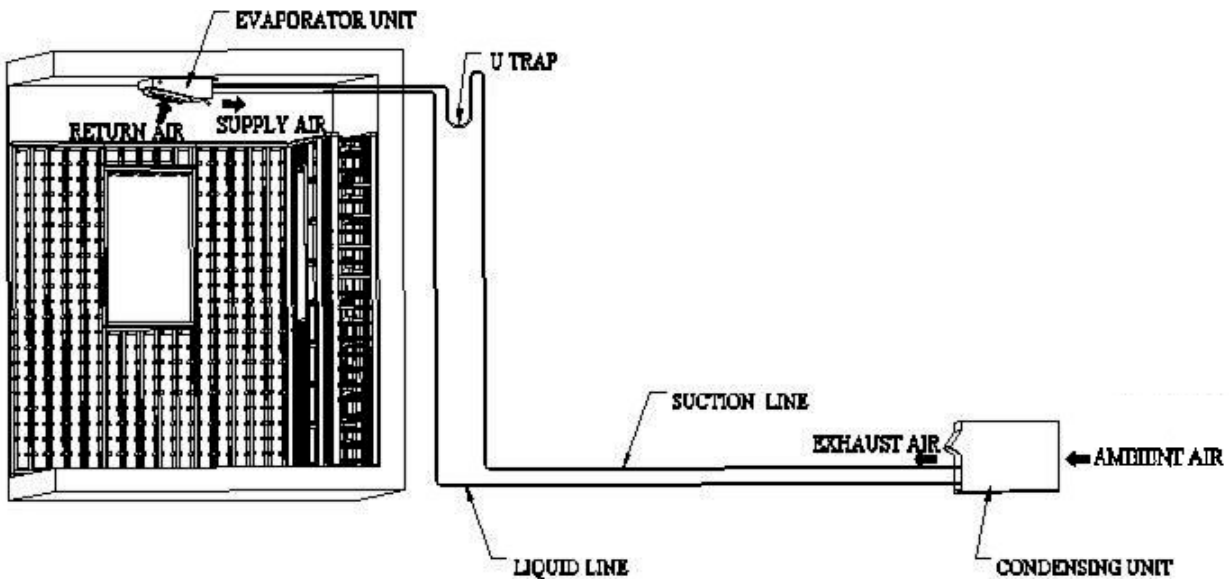

Fig. 1 SSL Split Low-Profile Cooling System

CAUTION	If the condensing unit will operate below 50°F, install a low ambient condition kit.
----------------	--

NOTE	The cooling capacity is determined under 55°F cellar temperature, 75°F cellar ambient temperature and 90°F condensing unit ambient temperature, with R13 interior and R19 exterior insulations. Higher ambient temperatures or lower insulations will cause reducing capacity and the cellar temperature may not be maintained at 55°F.
-------------	---

The specifications are listed as follows:

Model No.	Capacity (Btu/h) / Airflow (CFM)	Max Cellar Size (cu ft)
WM-1500SSL WM-1500SSL-LA	1500 / 180	150
WM-2500SSL WM-2500SSL-LA	2500 / 275	250
WM-4500SSL WM-4500SSL-LA	4500 / 460	1000
WM-6500SSL WM-6500SSL-LA	6500 / 575	1500
WM-8500SSL WM-8500SSL-LA	8500 / 834	2000

NOTE	“LA” refers the unit equipped with a low ambient kit.
-------------	---

For further info, see Fig. 3~7.

Temperature and Humidity

1. The controller



Fig. 2 TEMPERATURE CONTROLLER

1) Keys

SET: To display set-point; in programming mode it selects a parameter or confirms an operation.

: To start a manual defrost.

: To see the maximum stored temperature; in programming mode it browses the parameter codes or increases the displayed value.

: To see the minimum stored temperature; in programming mode it browses the parameter codes or decreases the displayed value.

: To turn on/off the power to the unit.

: To lock/unlock the keypad.

SET+ : To enter in the programming mode.

SET+ : To return to the temperature display.

2) Lock and unlock the keys

To lock the keys, press up + down keys until POF is displayed; to unlock the keys, press up + down keys until PON is displayed.

3) Display

During normal operating conditions, the display shows the value measured by the air temperature probe. In case of active alarm, the temperature flashes alternately to the code alarm. The LED functions are listed as follows.

LED	MODE	FUNCTION
	ON	Compressor enabled
	Flashing	Anti-short cycle enabled
	ON	Defrost enabled
	ON	Fan enabled
	Flashing	Fan delay after defrost enabled
	ON	Alarm occurring
°C/°F	ON	Temperature measuring unit
°C/°F	Flashing	Programming mode

4) Alarm Signals

The alarm codes are described as follows.

MESSAGE	CAUSE	FUNCTION
P1	Temperature probe faulty	Compressor switching to Con and CoF
HA	High temperature alarm	Probe temperature ALU higher than the setting temperature; Outputs unchanged
LA	Low temperature alarm	Probe temperature ALL lower than the setting temperature; Outputs unchanged
CA	External alarm	All outputs off

Probe alarms P1”, start a few seconds after the fault in the related probe; they automatically stop a few seconds after the probe restarts normal operation. Check connections before replacing the probe. Temperature alarms “HA”, “LA” automatically stops as soon as the temperature returns to normal value. Alarm “CA” (with i1F=PAL) recovers only by switching off and on the instrument.



2. Temperature Setting

- Set the temperature at 55 °F for the optimum aging of wine
- On initial start-up, the time required to reach the desired temperature will vary, depending on the quantity of bottles, temperature setting and surrounding temperature.
- Allow 24 hours to stabilize the temperature for each new temperature setting operation

3. How to see temperature set-point

- 1) Press and immediately release the **SET** key, the display will show the set-point value.
- 2) Press again and immediately release the **SET** key to display the probe value.

4. How to change the set-point







- 1) Press and hold the **SET** key until the “°C” or “°F” LED starts flashing and the set-point is displayed.
- 2) Press the up/down keys / to change the set-point value within 10 sec.
- 3) Press the **SET** key again to store the new set-point value.

NOTE	The unit turns on at set-point Set plus regulation differential Hy after anti-short cycle AC has elapsed; the unit turns off at set-point Set .
-------------	---

5. Manual Defrost

Press and hold the defrost ❄️ key until defrost starts. The defrost indicator will be on.

6. Parameter Programming

- 1) Press and hold the **SET** +  keys until the “°C” or “°F” LED starts flashing, then release the keys.
- 2) Press and hold again the **SET** +  keys until the **Pr2** label is displayed, then release the keys. The first parameter **Hy** will be displayed.
- 3) Press up/down keys / to scroll to the required parameter within 10 sec.
- 4) Press the “**SET**” key to display its value.
- 5) Use up/down keys / to change its value within 10 sec.
- 6) Press “**SET**” to store the new value and the display will flash 3 times.
- 7) **To exit:** Press **SET** +  or wait 15sec without pressing a key.

PARAMETER	DESCRIPTION	DEFAULT VALUE
Set	set-point (°)	55
Hy	temperature regulation differential (°)	4
AC	anti-short cycle delay (min)	10 (hidden)
Con	compress on with probe faulty (min)	15
CoF	compress off with probe faulty (min)	30
CF	temperature unit (°F/ °C)	F: Fahrenheit
rES	display resolution	in: integer
dLy	temperature display delay (min)	1
ot	probe calibration (°)	0
LS	minimum set-point (°)	50
US	maximum set-point (°)	65
idF	defrost interval time (hour)	12
MdF	defrost endurance time (min)	30
ALC	temperature alarm type	rE: relative to set-point
ALU	high temperature alarm (°)	10
ALL	low temperature alarm (°)	10
AFH	alarm recovery differential (°)	5
ALd	temperature alarm delay (min)	60
dAO	temperature alarm delay on startup (hr)	23
SAA	heater set-point (°)	40
SHy	heater regulation differential (°)	4
FSU	fan action	Std
FnC	fan operating mode	C-n: on with compressor & off during defrost
Fon	fan on with compressor off (min)	0
FoF	fan off with compressor off (min)	15

NOTE

Depending on the controller, not all parameters are available.

7. How to calibrate the air probe

If the actual cellar temperature differs from the setting temperature, set parameter **ot** = actual cellar temperature minus set-point.

8. How to adjust defrost settings

In case there is excessive frost, the parameters **FnC** = C-y, **idF** = 4 and **MdF** = 20 can be used to avoid frost.

9. How to adjust the humidity

The parameter **Fon** is used to adjust the humidity in the wine cellar. Higher **Fon** results in higher relative humidity. Use a separate hygrometer to monitor the humidity.

10. How to set alarm call

- 1) Speech notice will be sent to your phones when the cellar temperature is **ALU** higher or **ALL** lower than the set-point **Set**.
- 2) In order to test the call function, set parameters **Ald** = 0 and **dAO** = 0. After testing, set **Ald** = 60 and **dAO** = 23.

11. How to set cellar heater

The heater turns on at **SAA** minus **Shy**; the heater turns off at **SAA**.

NOTE	Use a forced air heater to warm up the wine cellar. If there is a thermostat on the heater, bypass it or set the thermostat at the highest level. If the heater runs more than 10 A current, use a 120VAC coil contactor.
-------------	---

Care Guide

 WARNING	
	ELECTRIC SHOCK HAZARD Disconnect the electrical power before servicing any components. Failure to do so can result in death or electrical shock.

In general, always unplug system or disconnect power while doing care.

1. Condenser Coil Cleaning

- Clean the condenser coil regularly. Coil may need to be cleaned at least every 6 months.
- Use a vacuum cleaner with an extended attachment to clean the coil when it is dusty or dirty.

2. Condensate Removing

- Remove the excessive condensate if it is accumulated in the wine cellar under high humidity conditions.

User's Troubleshooting

This Troubleshooting Chart is not prepared to replace the training required for a professional refrigeration service person, not is it comprehensive.

Complaint	Possible Causes	Response
1. Unit not running	<ul style="list-style-type: none"> a. Power cord not plugged b. No power from supply c. Incorrect or loose wirings d. Low voltage e. Setting higher than ambient temperature f. Waiting for cut-in g. Defrost light blinking h. Compressor light blinking i. Defective controller 	<ul style="list-style-type: none"> a. Check power cord b. Check receptacle and fuses c. Check all wirings and connections d. Contact an authorized electrician e. Lower temperature setting f. Wait g. Unit is under defrost mode h. Unit is under anti-short cycle delay i. Call service for diagnosis
2. Unit not starting , but temperature rising high	<ul style="list-style-type: none"> a. Anti-short cycle 	<ul style="list-style-type: none"> a. Reset AC
3. Temperature fluctuating	<ul style="list-style-type: none"> a. Air probe 	<p>a. When using an air probe, the wine bottle temperature is mainly controlled by the average air temperature. If the set-point is 55°F with the differential 4F, the cooling unit turns on at 59°F of air temperature (It may be higher than 59°F if it is in anti-short cycle or defrost) and turns off at 55°F of air temperature. The average air temperature is 57°F, and then the wine temperature is around 57+/- 0.5°F. The air is light enough to change so quickly that it maintains relatively constant average temperature that would prevent wine bottle temperature from fluctuating.</p>
4. Temperature high, unit stopping and starting normally	<ul style="list-style-type: none"> a. Temperature setting high 	<ul style="list-style-type: none"> a. Lower the setting
5. Temperature high, unit stopping and starting with short running time	<ul style="list-style-type: none"> a. Air probe touching the evaporator coil, displaying temperature ok b. Air probe in cold-air supply, displaying temperature ok c. Failed controller and probe 	<ul style="list-style-type: none"> a. Move the air probe away from the evaporator b. Move the air probe away from the cold-air supply c. Call service for diagnosis
6. Temperature high or not cooling and running continually	<ul style="list-style-type: none"> a. Improper cellar insulation & seal b. Cellar too large c. Ambient temperature too high d. Exhaust restricted 	<ul style="list-style-type: none"> a. Check insulation, gasket and door opening b. Check for excessive size c. Check installation location d. Leave minimum 3 feet clearance for the hot air exhaust side and leave

	<ul style="list-style-type: none"> e. Malfunctioning fans f. Evaporator or condenser airflow g. Dirty Condenser h. Iced evaporator i. Refrigeration system restriction j. Refrigerant leak k. Undercharge or overcharge l. Failed components 	<p>minimum 1 foot clearance for the ambient air intake side</p> <ul style="list-style-type: none"> e. Check for both evaporator and condenser fans f. Check for air restrictions, air short-circulation, grille directions g. Clean condenser h. Defrost and reset temperature i. Call service j. Call service k. Call service l. Check compressor windings, start relay and overload protector
7. Unit running too long	<ul style="list-style-type: none"> a. Improper cellar insulation & seal b. Exhaust restricted c. Cellar too large d. Ambient temperature > 90°F e. Dirty Condenser f. Improper condenser air flow 	<ul style="list-style-type: none"> a. Check insulation, gasket and door opening b. Leave minimum 3 feet clearance for the hot air exhaust side and leave minimum 1 foot clearance for the ambient air intake side c. Check for excessive size d. Check for installation location e. Clean condenser f. Check for fan and air short circulation
8. Condenser fan running but compressor not running	<ul style="list-style-type: none"> a. Incorrect or loose wirings b. Failed components c. Liquid refrigerant in the compressor 	<ul style="list-style-type: none"> a. Check all wirings and connections b. Check start relay, start capacitor, overload protector, compressor. c. Call service.
9. Compressor running but condenser fan not running	<ul style="list-style-type: none"> a. Fan blade stuck b. Incorrect or loose wirings c. Failed motors d. Fan cycle control 	<ul style="list-style-type: none"> a. Check for proper clearance b. Check all wirings c. Call service d. Check for setting
10. Temperature high, compressor stopping and starting but very short running time	<ul style="list-style-type: none"> a. Failed components b. Improper condenser airflow c. Dirty condenser d. Overcharge of refrigerant e. Discharge or suction pressure too high 	<ul style="list-style-type: none"> a. Check compressor windings, start relay and overload protector. b. Check for condenser fan c. Clean condenser d. Call service for removing refrigerant e. Call service for information
11. Evaporator fan running too long	<ul style="list-style-type: none"> a. Post-compressor fan running mode for humidity modulation 	<ul style="list-style-type: none"> a. Reset FON
12. Evaporator fan running but condensing unit not running	<ul style="list-style-type: none"> a. Incorrect or loose wirings b. Failed components c. Low refrigerant 	<ul style="list-style-type: none"> a. Check all wirings and connections b. Check start relay, start capacitor, overload protector, compressor. c. Call service
13. Temperature low	<ul style="list-style-type: none"> a. Low temperature setting b. Low ambient temperature c. Air probe fault d. Temperature controller fault 	<ul style="list-style-type: none"> a. Raise the setting b. Move to another location c. Check probe connections or change a new one d. Change a new one
14. Evaporator freezing up	<ul style="list-style-type: none"> a. Evaporator air flow restriction b. Condenser air flow restriction 	<ul style="list-style-type: none"> a. Check for fans and CFM b. Check for fans and CFM

	<ul style="list-style-type: none"> c. Not stopping due to air leak, high ambient temperature or low temperature setting d. Defective controller or probe e. Low ambient temperature f. Initially working then stopping, moisture in the system g. Refrigerant low or leaking h. Expansion valve blockage 	<ul style="list-style-type: none"> c. Check for seal, door opening, ambient temperature and temperature setting d. Check for controller and probe e. Change defrost settings f. Call service g. Call service h. Call service
15. Water leak	<ul style="list-style-type: none"> a. Air leak in the wine cellar causing excessive condensate b. High humidity causing excessive condensate c. Evaporator air flow restriction d. Drain restricted or unit not level, and water overflowing e. Drip tray leak (No overflow but leak) 	<ul style="list-style-type: none"> a. Check for air leak b. Use drain line c. Check supply air flow or air TD d. Clean the drip tray and drain line e. Seal the leak using silicone sealant
16. Excessive condensate in wine cellar	<ul style="list-style-type: none"> a. Air leak in the wine cellar causing excessive condensate b. High humidity causing excessive condensate c. Drain restricted 	<ul style="list-style-type: none"> a. Check for any air leak b. Use drain line c. Clean the drip tray and drain line
17. Condensate inside ducts	<ul style="list-style-type: none"> a. Drain line restricted b. Continually running not stopping c. Too cold supply air 	<ul style="list-style-type: none"> a. Check for drain b. raise temperature setting or increase defrost c. Increase air flow or raise temperature setting
18. Condensate outside ducts	<ul style="list-style-type: none"> a. Duct not insulated b. High humidity c. Too cold supply air 	<ul style="list-style-type: none"> a. Check for insulation b. Use dehumidifier c. Increase air flow or raise temperature setting
19. Circuit tripping	<ul style="list-style-type: none"> a. Incorrect fuse or breaker b. Incorrect wirings c. Failed components 	<ul style="list-style-type: none"> a. Check for proper fuse or breaker b. Check for wirings and connections c. Call service
20. Noisy operation	<ul style="list-style-type: none"> a. Mounting area not firm b. Loose parts c. Compressor overloaded due to high ambient temperatures or airflow restriction d. Defective components 	<ul style="list-style-type: none"> a. Add support to improve installation b. Check fan blades, bearings, washers, tubing contact and loose screws. c. Check for airflow d. Call service for checking internal loose, inadequate lubrication and incorrect wirings

Installer's Instructions

WARNING

Do not use a ground fault interrupter (GFI). A dedicated circuit is required.

WARNING



- Always check wiring harness connections before initiating any test procedures.
 - Disconnect electric power from the appliance before performing any maintenance or repairs.
- Voltage checks should be made by inserting meter probes beside the wires in the connector blocks with the electric power source on and the connector block plugged in.
- Resistance checks should be made on components with the electric power off and the connector block disconnected.

Federal law requires that WINE~MATE split cooling systems be installed by an EPA certified refrigeration technician.

1. General Instructions

WINE~MATE split system is shipped as components and is ready for use only after a certified refrigeration technician has properly installed the system. Proper installation is critical. Vinotemp can only warrant the quality of the components. The installation and proper operation of the system must be warranted by the installer. Installation of the system must be done in accordance with all state and local building and electrical codes.

The condensing unit and evaporator unit are connected by a liquid line and an insulated suction line that are supplied by the installer. These lines must be properly sized for the distance between the two units. After the units and lines are connected, the system must be checked for restriction, pressurization and leak. Then the system must be evacuate and charged with refrigerant. Refrigerant amount will vary depending on the length of line set.

Parts included:

Temperature Controller

Evaporator Unit (liquid line solenoid valve and expansion valve are installed)

Condensing Unit (discharge, suction valves and pressure controls are installed)

Liquid Filter

Liquid Indicator

Parts not included:

Liquid line copper tubing
Suction line copper tubing

CAUTION	Liquid and suction line locations may differ from that they are shown below, please check on the units for proper installations.
----------------	--

NOTE	To prepare rough-in, leave minimum 4" clearances for electrical wiring and refrigeration piping.
-------------	--

Model No.	Evap Unit W" x D" x H"- A"xB"	Cond Unit L" x W" x H"	Electrical Rating Evap Unit / Cond Unit	Min Circuit Ampacity	Weight (lb) Evap Unit / Cond Unit
WM-1500SSL	WM-15SFCL 16.75 x 14.5 x 4.75- 14.75 x 14.75	WM- 150SCUR 18 x 14 x 12	115V-60HZ-1A 115V-60HZ-4A	20A	15 / 30
WM-1500SSL- LA	WM-15SFCL 16.75 x 14.5 x 4.75- 14.75 x 14.75	WM- 150SCUR- LA 18 x 14 x 12	115V-60HZ-1A 115V-60HZ-5A	20A	15 / 30
WM-2500SSL	WM-25SFCL 31.75 x 14.5 x 4.75- 29.75 x 14.75	WM- 250SCUR 18 x 14 x 12	115V-60HZ-1A 115V-60HZ-5A	20A	29 / 40
WM-2500SSL- LA	WM-25SFCL 31.75 x 14.5 x 4.75- 29.75 x 14.75	WM- 250SCUR- LA 18 x 14 x 12	115V-60HZ-1A 115V-60HZ-6A	20A	29 / 40
WM-4500SSL	WM-45SFCL 40.25 x 14.5 x 4.75- 38.25 x 14.75	WM- 450SCUR 18 x 14 x 12	115V-60HZ-1A 115V-60HZ-6A	20A	37 / 60
WM-4500SSL- LA	WM-45SFCL 40.25 x 14.5 x 4.75- 38.25 x 14.75	WM- 450SCUR- LA 18 x 14 x 12	115V-60HZ-1A 115V-60HZ-7A	20A	37 / 60
WM-6500SSL	WM-65SFCL 53.75 x 16.5 x 6.75- 51.75 x 16.75	WM- 650SCUR 24 x 18 x 18	115V-60HZ-2A 115V-60HZ-12A	30A	61 / 90
WM-6500SSL- LA	WM-65SFCL 53.75 x 16.5 x 6.75- 51.75 x 16.75	WM- 650SCUR- LA 24 x 18 x 18	115V-60HZ-2A 115V-60HZ-13A	30A	61 / 90
WM-8500SSL	WM-85SFCL 64.25 x 18.25 x 9- 53.25 x 19.3125	WM- 850SCUR 24 x 18 x 18	115V-60HZ-2A 115V-60HZ-15A	30A	80 / 115
WM-8500SSL- LA	WM-85SFCL 64.25 x 18.25 x 9- 53.25 x 19.3125	WM- 850SCUR- LA 24 x 18 x 18	115V-60HZ-2A 115V-60HZ-16A	30A	80 / 115

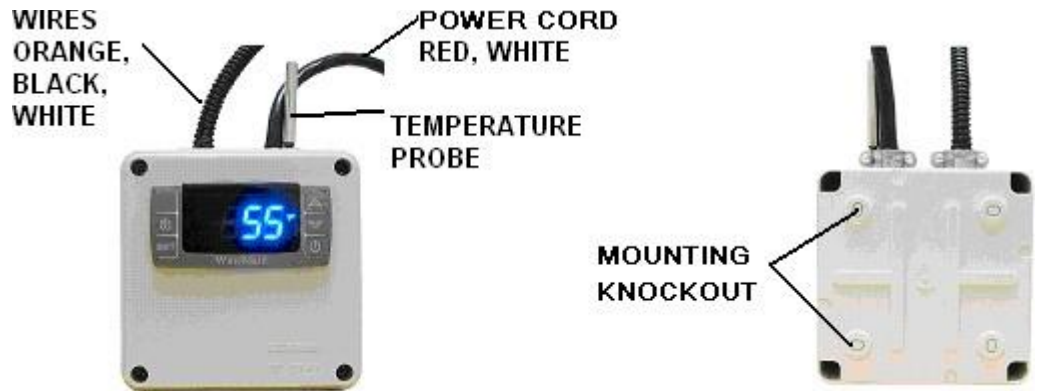
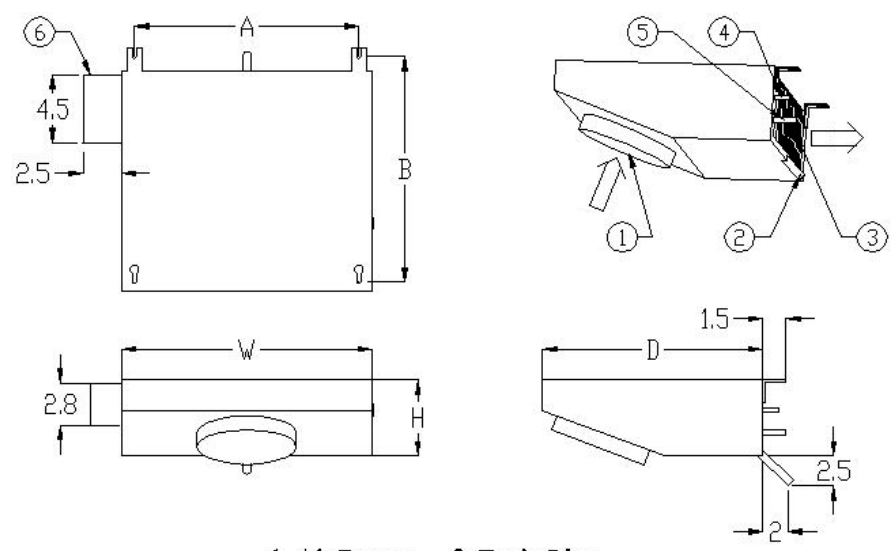
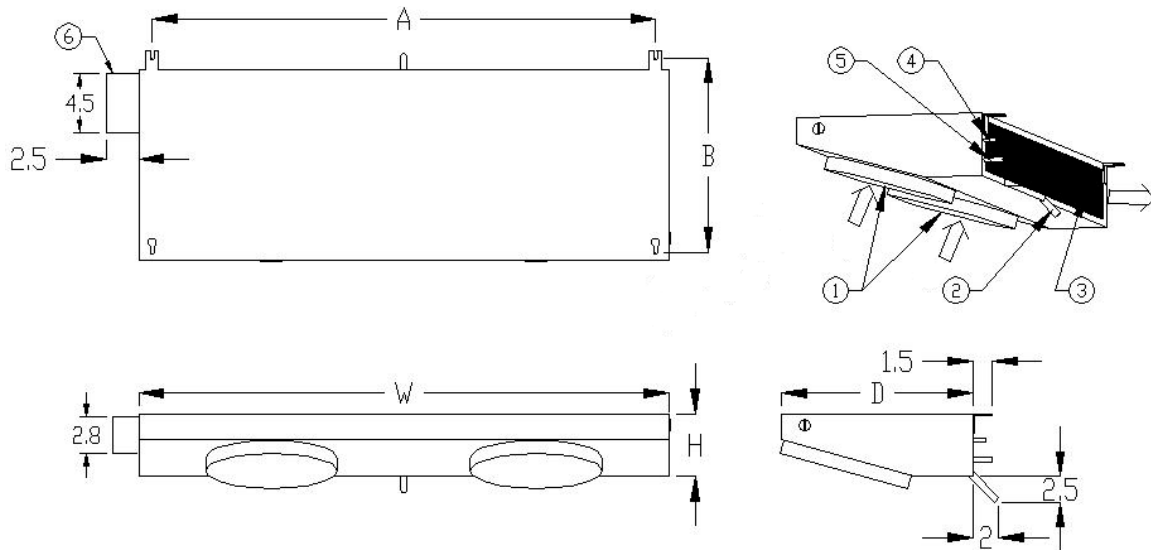

Fig. 3 Temperature Controller (4.5”L X 4.5”W X 3.75H)



- 1. Air Return 2. Drain Line
- 3. Air Supply 4. Liquid Line
- 5. Suction Line 6. Outlet

Fig. 4 WM-15~25SFCL Evaporator Unit



- 1. Air Return
- 2. Drain Line
- 3. Air Supply
- 4. Liquid Line
- 5. Suction Line
- 6. Outlet

Fig. 5 WM-45~85SFCL Evaporator Unit

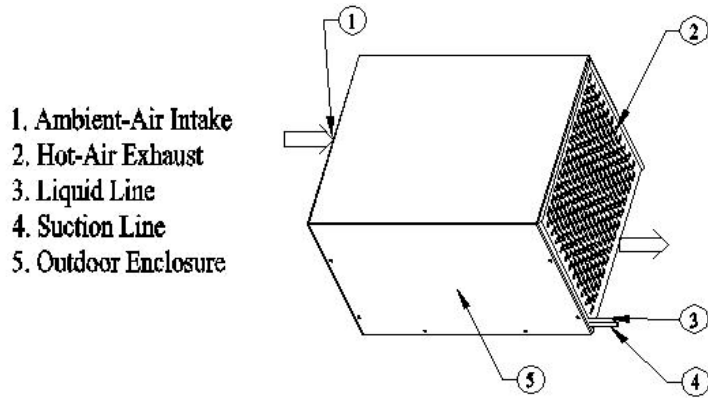

- 1. Ambient-Air Intake
- 2. Hot-Air Exhaust
- 3. Liquid Line
- 4. Suction Line
- 5. Outdoor Enclosure

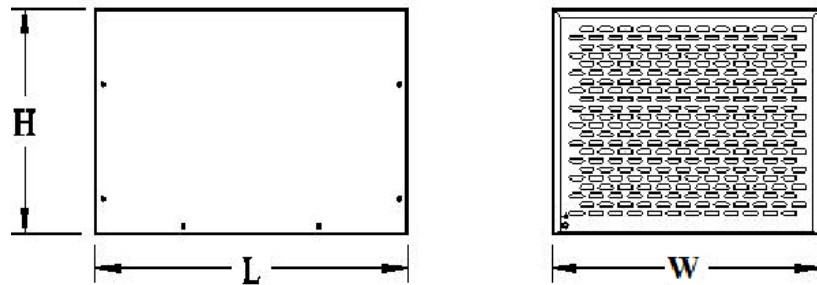

Fig. 6 WM-150~450SCUR Condensing Unit

1. Ambient-Air Intake
2. Hot-Air Exhaust
3. Outdoor Enclosure

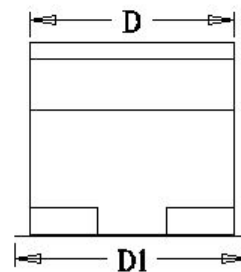
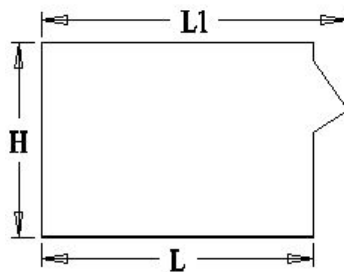
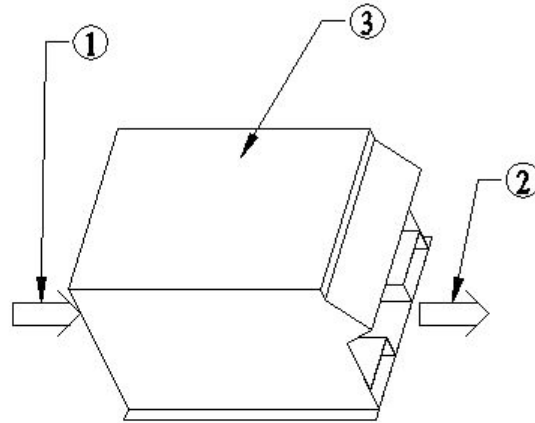

Fig. 7 WM-650~850SCUR Condensing Unit



Fig. 8 WM-Liquid Filter



Fig. 9 WM-Liquid Indicator

2. Temperature Controller and Air Probe Location

- 1) The temperature controller can be mounted either inside or outside the wine cellar, but the air probe must be located inside.
- 2) The air probe shall be located in the wine cellar 5 ft above the floor or the air return area, but it shall not be located in the air supply area or other areas where air is not circulated.
- 3) Air probe can be pulled out of the temperature controller up to 5 ft. If additional wires are necessary, 18 gauge wires may be used to extend the airprobe.

3. Evaporator Unit Location

- 1) The WM-15~85SFCL evaporator units shall be installed for ceiling mount with the supply air toward horizontal and return air on the bottom. The units may

be recessed in the ceiling with short curved rectangular ducts in air supply, but the air flow CFM must be checked.

- 2) For a direct blow application, air supply shall be unobstructed minimum 12". For a deflector application, leave 2" clearance for air supply. Air return shall be unobstructed minimum 6".
- 3) There is a gravity drain system, so the unit shall be installed level or with a slight slope downward the drain connection and the drain line shall be installed slope down toward the drain. If rise-up is necessary, a condensation pump must be used.

4. Condensing Unit Location

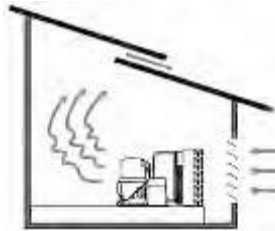

CAUTION

Low ambient condition kit is required if the temperature will be below 50°F.

- 1) Place the condensing units WM-150~850SCUR in a properly ventilated location. Otherwise, heat exhausted by the condensing unit will build up and the cooling system will not operate properly.
- 2) Condensing unit shall be elevated to avoid possible flooding and shaded from direct sun. It shall not be exposed to temperatures higher than 110 °F or lower than 50 °F.
- 3) Leave minimum 5 ft clearance for the air exhaust side and leave minimum 1 foot clearance for the air intake side.

5. Refrigeration Piping and Leak Testing

NOTE

The line connector sizes of liquid filter and indicator, the valve connector sizes of condensing unit or the line connector sizes of evaporator unit may not be the same as the listed refrigeration line sizes.

If the condensing unit is installed above the evaporator unit, use the suction line one size smaller.

Expansion and solenoid valves have been installed on the liquid line in the evaporator unit.

The line sizes and refrigerant charges are listed as follows.

Model No.	Equivalent Line Set	Liquid Line	Suction Line	Drain Line	Recommended Initial Charge
WM-1500SSL WM-1500SSL-LA	<= 75 FT	1/4" OD	3/8" OD	1/2" OD	R134a / 15 OZ
WM-2500SSL WM-2500SSL-LA	<= 75 FT	1/4" OD	3/8" OD	1/2" OD	R134a / 19 OZ
WM-4500SSL WM-4500SSL-LA	<= 75 FT	1/4" OD	1/2" OD	1/2" OD	R134a / 26 OZ
WM-6500SSL WM-6500SSL-LA	<= 75 FT	1/4" OD	1/2" OD	1/2" OD	R134a / 32 OZ
WM-8500SSL WM-8500SSL-LA	<= 75 FT	3/8" OD	5/8" OD	1/2" OD	R134a / 40 OZ

- 1) The piping starts from □ condensing unit's receiver discharge valve □ liquid filter □ liquid indicator □ liquid line □ to evaporator unit's liquid line connection (assembled with solenoid valve and expansion valve) □ suction line connection □ insulated suction line □ to condensing unit's suction valve.
- 2) If the line set exceeds 75 ft long, use both inverted U trap and suction accumulator to prevent liquid from flooding back to the compressor.
- 3) If the condensing unit is located below the evaporator unit, use inverted U trap to prevent liquid from flooding back to the compressor. If the elevation difference is more than 10 ft, use both inverted U trap and suction accumulator.
- 4) If the condensing unit is located more than 10 ft above the evaporator unit, use U trap to aid oil returning to the compressor.
- 5) Complete pipe brazing, check solenoid valve and expansion valve restrictions and perform leak testing.
- 6) Hook up the drain line and check if water drains.

6. Connecting Electrical Wires

Connect all electrical components using the wiring diagrams in accordance with all state and local codes.

7. Evacuating, Charging and Starting the System

1-Manifold High or Low Pressure Hose; 2-Receiver Discharge or Compressor Suction Port; 3-Liquid or Suction Line; 4-Pressure Control;

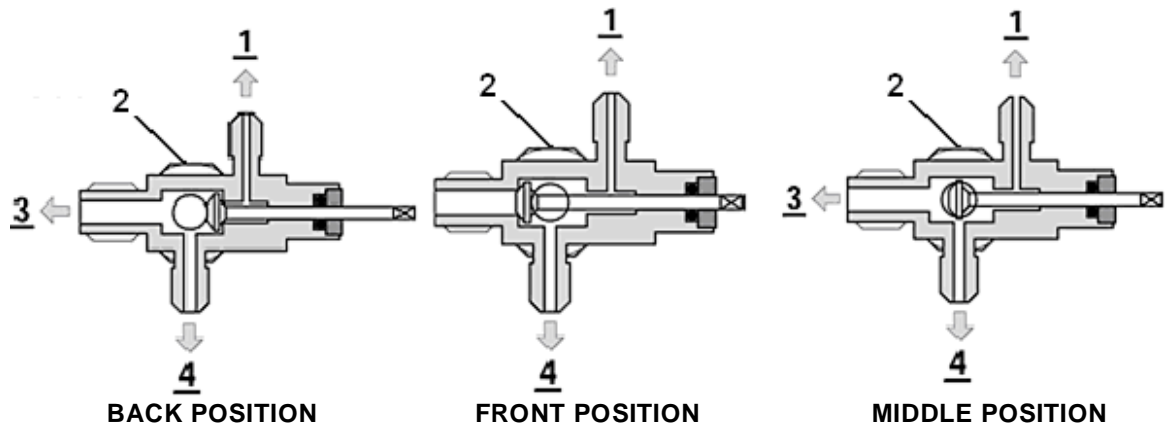

Fig. 10 ROTALOCK Valve Operation

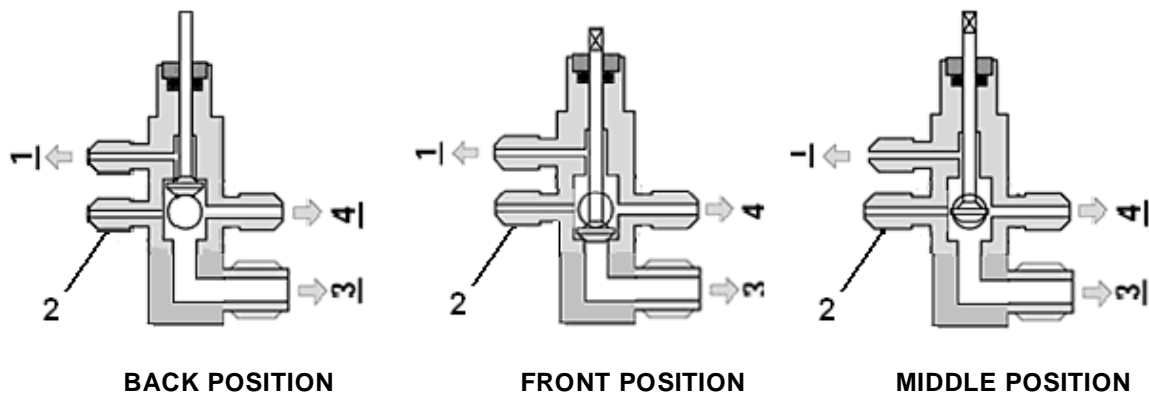

Fig. 11 Base Valve Operation

Back Position: Normal operation, manifold port is closed.

Front Position: Storage operation, liquid or suction line connection is closed.

Middle Position: Installation operation, all ports are open.

NOTE	<p>The recommended initial charges are used for reference only, always use the superheat, subcooling and pressure readings to charge refrigerant properly.</p> <p>If the unit is equipped with a low ambient condition kit and installed in the summer, add 15% more refrigerant.</p> <p>If the low ambient condition kit is used, turn off the compressor before power the condensing unit. Only turn on the compressor after the condensing unit has been powered for 12 hours.</p>
-------------	---

- 1) Turn both discharge and suction valves in the middle positions.
- 2) Connect the manifold high or low pressure hose to the discharge or suction valve and connect it to a vacuum pump.
- 3) Open the manifold high and low pressure valves to evacuate the system.

- 4) Close the manifold high and low pressure valves and switch it to a charging scale.
- 5) Open the manifold high and low pressure valves to charge the system using the recommended initial charge.
- 6) Close the manifold high and low pressure valves. Turn on the power to start the system.
- 7) Check the following temperatures and pressures.

8. Adjusting and Completing the Installation

1) Checking pressure control settings

I. The encapsulated pressure control (if applicable)

Suction pressure setting (fixed): Cut in = 32 psig; Cut out = 10 psig;

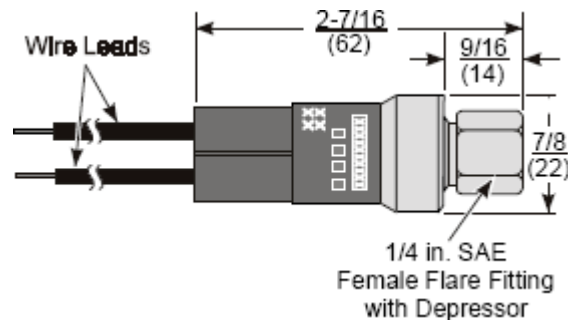
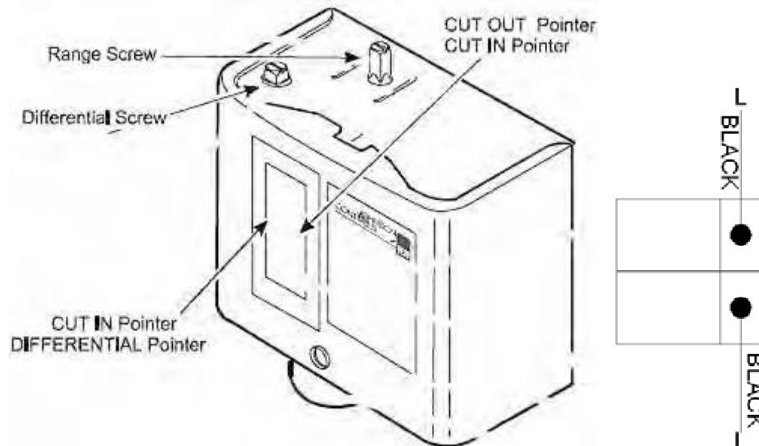

Fig. 12 Fixed Pressure Control

II. The adjustable pressure control (if applicable for pump-down)

Suction pressure setting: Cut out=5 psig; Cut in=25 psig; Differential=20 psig
 Head pressure setting: Cut out=230 psig; Cut in=150 psig; Differential=80 psig
 It is necessary to adjust the setting in the field to reach the correct cycle time.

A. P70 Single/Dual Control



B. PS2 Dual Control

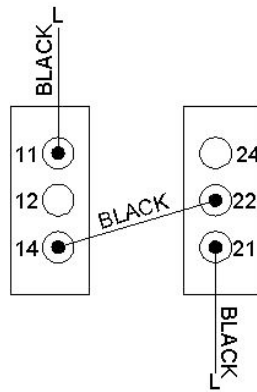

Fig. 13 Adjustable Pressure Control

III. Low ambient condition kit (if applicable)

A. The crankcase heater

The crankcase heater is installed at the bottom of the compressor and shall be turned on all the time. The heater is self-regulated.

B. The condenser fan control

The condenser fan control is installed at the high side. It closes on rise of pressure. It is necessary to adjust the setting in the field to avoid fan short cycle.

Head pressure setting: Cut in=170 psig; Cut out=110 psig; Differential=60 psig;

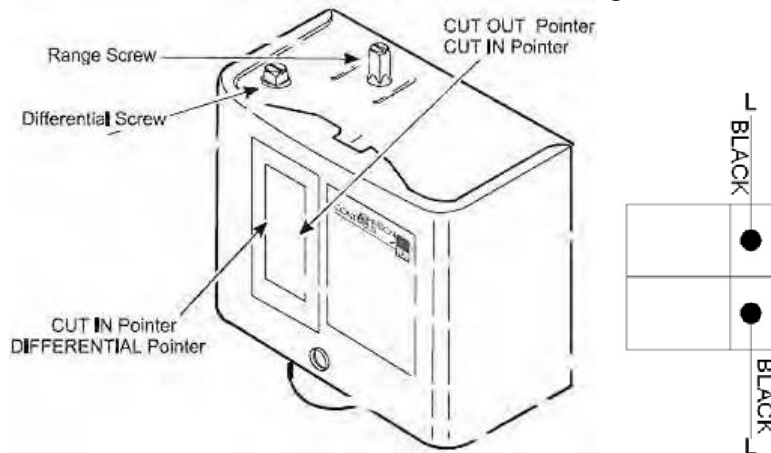

Fig. 14 Condenser Fan Cycle Control

- 2) The subcooling at the condensing unit shall be around 10°F. The charge may be complete when there are no more bubbles forming in the liquid indicator.
- 3) The head pressure shall be 120 ~ 150 psig at 70 ~ 90 °F condensing unit operating temperatures.
- 4) The evaporator's constant pressure expansion valve is set around 30 ~ 35 psig (35 ~ 40°F) at factory. This pressure setting gives a dew point to maintain the proper humidity for storing wine.
- 5) The temperature split across the evaporator shall be 8 ~ 10°F at 55°F wine cellar temperature.
- 6) Again, you must verify if the superheat at the evaporator unit is 9 ~ 18°F at 55 °F ~ 65 °F wine cellar temperatures.
- 7) If the superheat is high, check the subcooling first to see if the refrigerant charge is sufficient. If the charge is not sufficient, add more refrigerant (Liquid must always be charged into the hide side when the compressor runs). If the charge is good, then increase the evaporator suction pressure by turning the hex nut (5/16") clockwise.
- 8) If the superheat is low, then decrease the evaporator suction pressure by turning the hex nut (5/16") counter-clockwise.

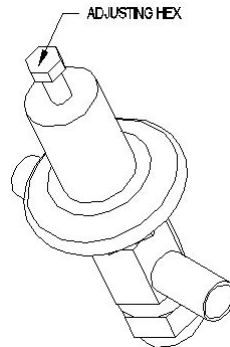

Fig. 15 Expansion Valve

- 9) Turn both discharge and suction valves in the back positions.
- 10) Disconnect the manifold.

9. Pressure, Superheat and Subcooling Readings

CAUTION	To read properly, the service valves must be in the middle positions.
----------------	---

Complaint	Possible Causes
1) High suction pressure and low headpressure Zero superheat and zero subcooling 2) High suction pressure and low headpressure Low superheat and low subcooling	1) Compressor may be bad 2) Expansion valve opened, too much oil

- 3) High suction pressure and high head pressure
Low superheat and high subcooling
- 4) High to normal suction pressure and high head pressure
Low subcooling
- 5) High suction pressure and high head pressure
Low superheat and low subcooling
- 6) High suction pressure and high head pressure
High superheat
- 7) Low suction pressure and low head pressure
High superheat and low subcooling
- 8) Low suction pressure and low to normal head pressure
High superheat and high subcooling
- 9) Low suction pressure and low head pressure
Normal to high superheat and low subcooling
- 10) Low suction pressure and low head pressure
Low superheat and low subcooling
- 11) Low suction pressure and low to normal head pressure
High superheat and normal to high subcooling
- 12) Low suction pressure and normal head pressure
High superheat and normal subcooling
- 13) Low suction pressure and high head pressure
High superheat and high subcooling
- 14) Low suction pressure and high head pressure
High superheat and high subcooling
- 15) low to normal suction pressure and high head pressure
Normal to high superheat and high subcooling

- 3) Overcharge
- 4) Non-condensable gas
- 5) Air restricted, dirty condenser, bad condenser fans
- 6) High cellar temperature, high evaporator load
- 7) Undercharge
- 8) Liquid line restricted after receiver, solenoid valve restricted
- 9) Suction line restricted
- 10) Air restricted at evaporator, evaporator iced
- 11) Evaporator restricted
- 12) Expansion valve restricted
- 13) Both evaporator and condenser restricted; liquid and suction lines connected wrong
- 14) Liquid line restricted before receiver
- 15) Condenser restricted

10. Condensing Unit Troubleshooting

Unit not running	
<ul style="list-style-type: none">1) Incorrect power supply2) Incorrect or loose wirings3) Failed components4) Low pressure switch shutting down the system5) high pressure switch shutting down the system	<ul style="list-style-type: none">1) Check for proper voltage2) Check all wirings and connections3) Check start relay, start capacitor, overload protector, compressor.4) Check for system restriction or low refrigerant5) Check for the condenser fan

Electrical Wiring Diagrams

CAUTION

Hidden lines are the field wirings
 Use minimum 14 gauge wires for power lines.
 If equipped with low ambient condition kit, use low ambient temperature wiring diagrams.
 A safety switch is always recommended for the condensing unit.

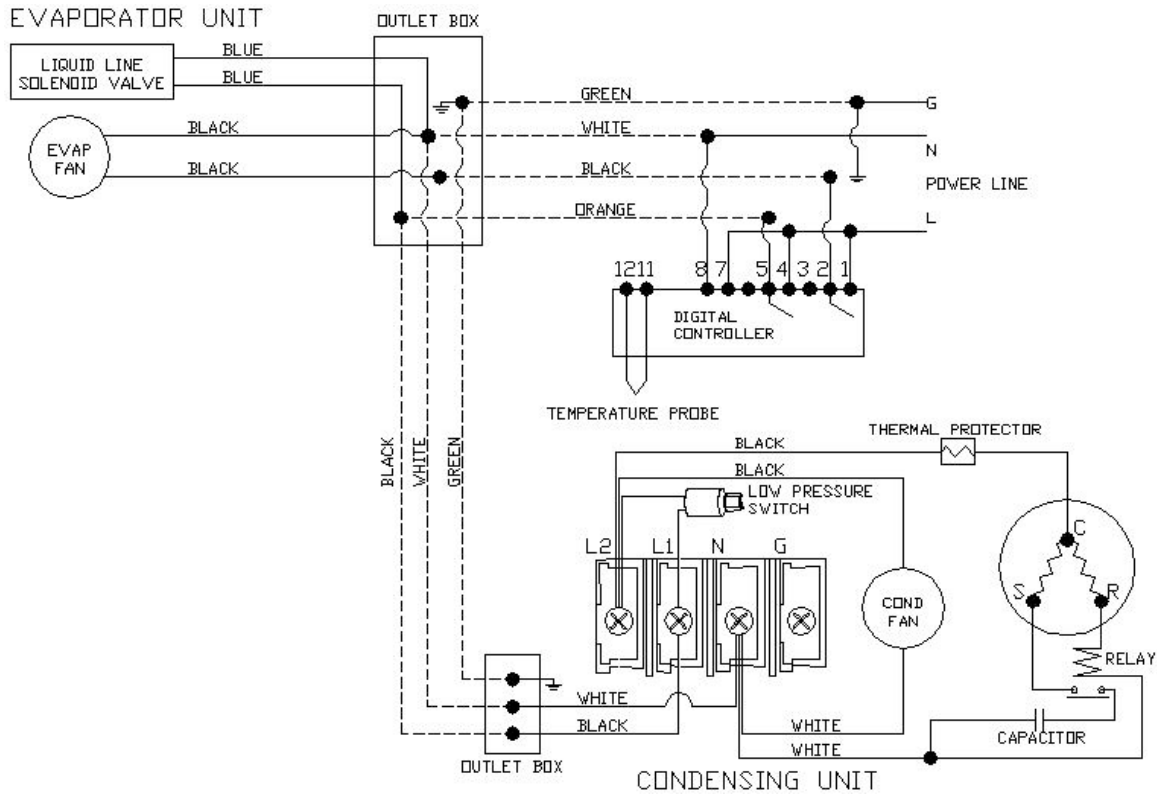

Fig. 16 WM-1500~4500SSL Electrical Wiring Diagram

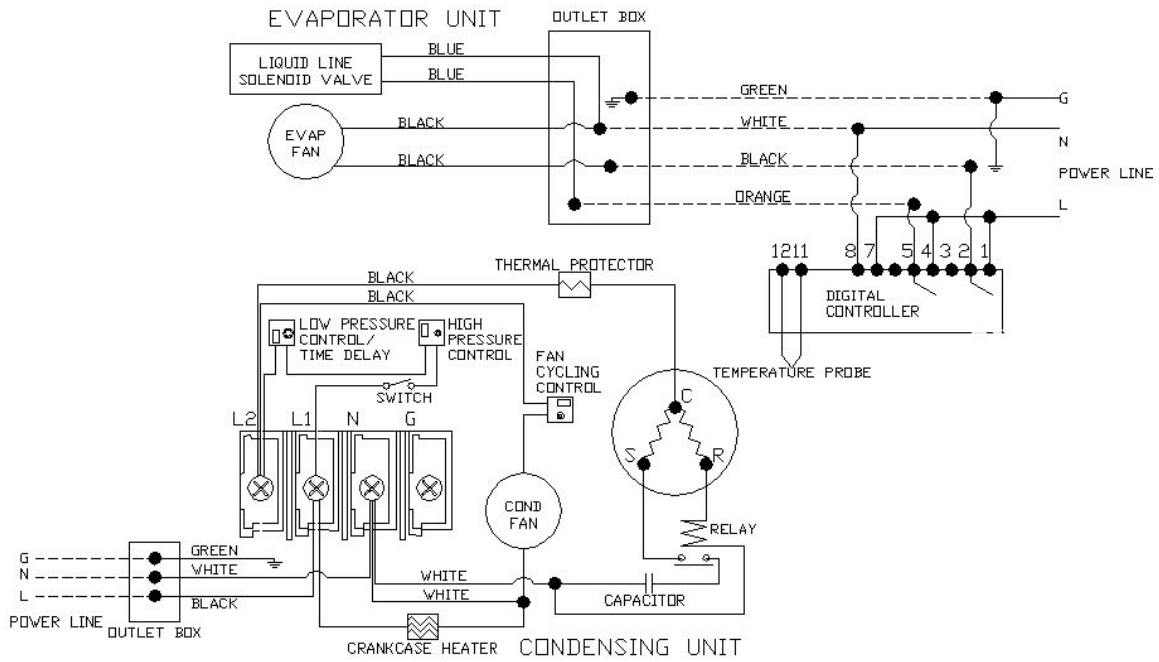

Fig. 17 WM-1500~4500SSL-LA Electrical Wiring Diagram

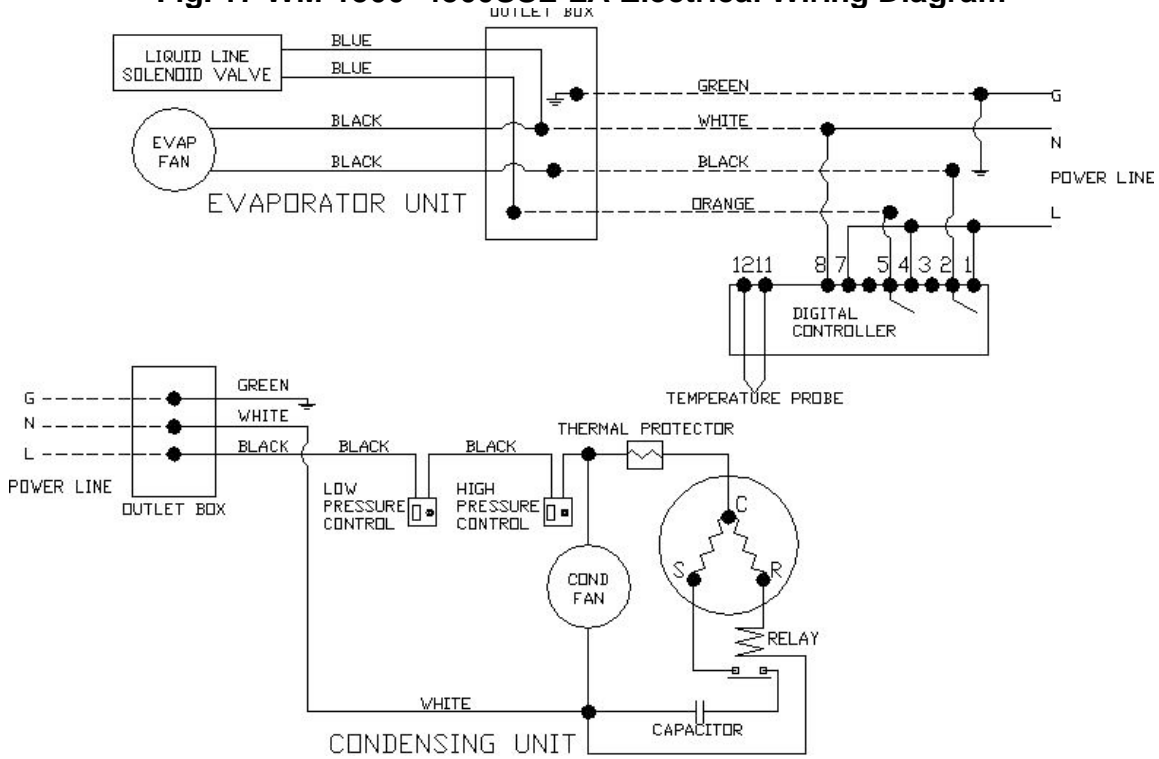

Fig. 18 WM-6500~8500SSL Electrical Wiring Diagram

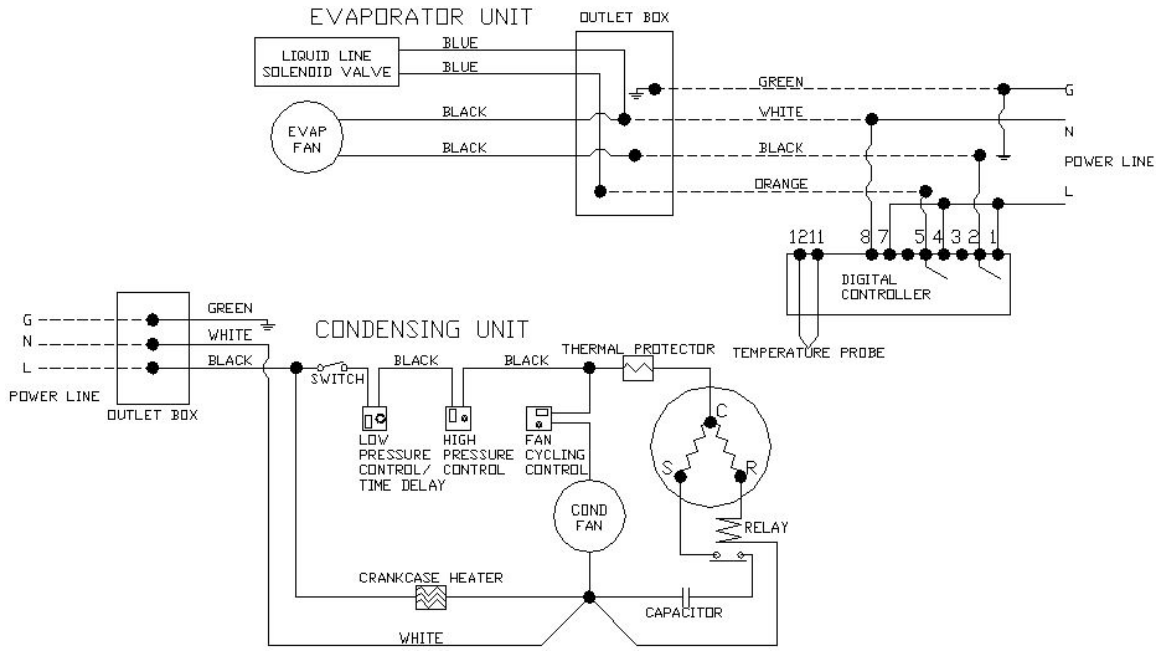

Fig. 19 WM-6500~8500SSL-LA Electrical Wiring Diagram

Warranty

Thank you for choosing a Vinotemp cooling unit.

Please enter the complete model and serial numbers in the space provided:

Model _____

Serial No. _____

Attach your purchase receipt to this owner's manual.

1. Limited Warranty

VINOTEMP warrants its products, parts only, to be free from defects due to workmanship or materials under normal use and service for twelve months after the initial sale. If the product is defective due to workmanship or materials, is removed within twelve months of the initial sale and is returned to VINOTEMP, in the original shipping carton, shipping prepaid, VINOTEMP will at its option, repair or replace the product free of charge.

This warranty constitutes the entire warranty of the VINOTEMP with respect to its products and is in lieu of all other warranties, express or implied, including any of fitness for a particular purpose. In no event shall VINOTEMP be responsible for any consequential damages what is so ever. Any modification of VINOTEMP products shall void this warranty.

Service under Warranty

This service is provided to customers within the continental UNITED STATES only. VINOTEMP cooling units are warranted to produce the stated number of BTU/H. While every effort has been made to provide accurate guidelines, VINOTEMP can not warranty its units to cool a particular enclosure.

In case of failure, VINOTEMP cooling units must be repaired by the factory or its authorized agent. Repairs or modifications made by anyone else will void the warranty.

Shall a VINOTEMP cooling unit fail, contact the dealer for instructions, do not return the unit to the factory without authorization from VINOTEMP. If the unit requires repair, re-pack it in the original shipping carton and return it to the factory, shipping prepaid. VINOTEMP will not accept COD shipments. If the unit

is determined to be faulty and is within the twelve month warranty period VINOTEMP will, at its discretion, repair or replace the unit and return it free of charge to the original retail customer. If the unit is found to be in good working order, or beyond the initial twelve month period, it will be returned freight collect.

2. Limitation of Implied Warranty

VINOTEMP'S SOLE LIABILITY FOR ANY DEFECTIVE PRODUCT IS LIMITED TO, AT OUR OPTION, REPAIRING OR REPLACING OF UNIT.

**VINOTEMP SHALL NOT BE LIABLE FOR:
DAMAGE TO OTHER PROPERTY CAUSED BY ANY DEFECTS IN THE UNIT,
DAMAGES BASED UPON INCONVENIENCE, LOSS OF USE OF THE UNIT,
LOSS OF TIME OR COMMERCIAL LOSS, ANY OUTER DAMAGES,
WHETHER INCIDENTAL, CONSEQUENTIAL OR OTHERWISE.**

THIS WARRANTY IS EXCLUSIVE AND IS IN LIEU OF ALL OTHER WARRANTIES, EXPRESSED OR IMPLIED, INCLUDING BUT NOT LIMITED TO, IMPLIED WARRANTIES OF MERCHANTABILITY OR FITNESS FOR A PARTICULAR PURPOSE.

While great effort has been made to provide accurate guidelines VINOTEMP cannot warrant its units to properly cool a particular enclosure. Customers are cautioned that enclosure construction, unit location and many other factors can affect the operation and performance of the unit. There for suitability of the unit for a specific enclosure or application must be determined by the customer and cannot be warranted by VINOTEMP.

Protect Your Investment with an Extended Warranty!



Add a New Leaf extended warranty to your order, and have the security of knowing that if there should be a problem, even years in the future, New Leaf will be there to assist! Usable for any Wine Cellar or other electronic device manufactured by Vinotemp. Add this warranty to purchases made from vinotemp.com or other qualified vendors. Warranty must be registered within the first 10 days from original purchase.

Visit www.vinotemp.com to purchase.