

Vinotemp®

A PROUD HERITAGE OF EXPERIENCE & QUALITY

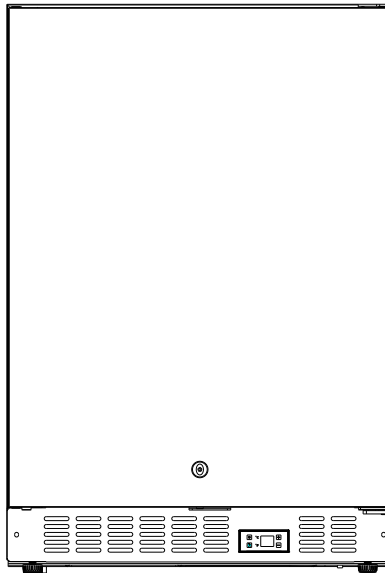

OUTDOOR/INDOOR FREEZER

VT-FZR240I

OWNER'S MANUAL



WWW.VINOTEMP.COM



General Operating Instructions

Remove all external and internal packaging from your appliance. Be sure that all parts have been included before discarding any packaging materials. You may want to keep the box and packing materials for use at a later date.

Upon receipt and inspection of unit, the supply cord must be replaced if it is damaged. Contact our customer service at 1-800-777-8466 or info@vinotemp.com.

READ ALL INSTRUCTIONS BEFORE USING THIS APPLIANCE
-Save these instructions-

To register your product, visit:
<http://www.vinotemp.com/Warranty.aspx>
Register your warranty within 10 days of receiving the unit.
Please be sure to retain your proof of purchase.

State of California Proposition 65 Warnings:

WARNING: This product can expose you to chemicals including BPA, Styrene, Nickel (Metallic) as well as some other products listed in the Prop 65 list used in making our appliances, which is known to the State of California to cause cancer and reproductive harm.

For more information go to www.P65Warnings.ca.gov

TABLE OF CONTENTS

IMPORTANT SAFETY INSTRUCTIONS	5
ELECTRICAL CONNECTION	6
PARTS AND SPECIFICATIONS	7
INSTALLATION	8
OPERATING YOUR APPLIANCE.....	9
CARE AND MAINTENANCE	12
TROUBLESHOOTING.....	14
TERMS OF SALE AND WARRANTY	16



I M P O R T A N T S A F E T Y I N S T R U C T I O N S



To reduce the risk of fire, electrical shock or injury when using your appliance, follow these basic precautions:

- Do not operate this or any other appliance with a damaged cord.
- Do not operate if housing is removed or damaged.
- Exercise caution and use reasonable supervision when appliance is used near children. Never allow children to operate, play with or crawl inside the appliance. Keep packing materials away from children.
- Before performing any maintenance or cleaning, ensure that the unit is unplugged or that the power line is disconnected.
- Do not clean appliance with flammable fluids. Do not store or use gasoline or other flammable vapors and liquids in the vicinity of this or any other appliance. The fumes can create a fire hazard or explosion.
- Exercise caution when moving and installing the unit. The cooler is heavy and may require two or more people when moving the unit to prevent strain or injury.
- To ensure proper ventilation for your appliance, the front of the unit must be completely unobstructed. Choose a well-ventilated area with temperatures above 44°F (7°C) and below 106°F (41°C).
- Locate the unit away from direct sunlight and sources of heat (stove, heater, radiator, etc). This unit is intended for indoor use only and must be installed in an area protected from the elements.
- Place the appliance on a solid, level surface.
- Do not attempt to repair or replace any part of your appliance unless it is specifically recommended in this manual. All other servicing should be referred to a qualified technician.
- Connect to properly polarized outlets only. It is recommended that a separate circuit, serving only your appliance be provided. Use receptacles that cannot be turned off by a switch or pull chain. Be sure that the plug is fully inserted into the receptacle.
- To protect against electric shock, do not immerse appliance, plug or cord in water or other liquids. Avoid locating the unit in moist areas.
- This appliance is designed to be built-in (fully-recessed) or freestanding for indoor or outdoor use.
- Do not use this appliance for other than its intended purpose.
- Do not operate the unit with wet hands, while standing on a wet surface or while standing in water.
- Do not use solvent-based cleaning agents or abrasives on the interior of the cooler. These cleaners may damage or discolor the interior.
- Keep fingers out of pinch point areas and be careful when closing doors if children are around.
- When disposing of refrigerated appliances, special handling is often required. It is the consumer's responsibility to comply with federal and local regulations when disposing of this product.
- This appliance is CFC- and HFC-free and contains small quantities of Isobutane (R600a) which is environmentally friendly, but flammable. It does not damage the ozone layer, nor does it increase the greenhouse effect. Care must be taken during transportation and setting up of the appliance that no parts of the cooling system are damaged. Leaking coolant can ignite and may damage the eyes.
In the event of any damage:
 - Avoid open flames and anything which creates a spark,

- Disconnect from the power supply,
- Air the room in which the appliance is located for several minutes and
- Contact the Service Department for advice.
- The more coolant there is in an appliance, the larger the room it should be installed in. In the event of a leakage, if the appliance is in a small room, there is the danger of combustible gases building up. For every ounce of coolant at least 325 cubic feet of room space is required. The amount of coolant in the appliance is stated on the data plate inside the appliance. It is hazardous for anyone other than an Authorized Service Person to carry out servicing or repairs to this appliance.
- Take serious care when handling, moving and using the appliance to avoid either damaging the refrigerant tubing or increasing the risk of a leak.
- Replacing component parts and servicing shall be done by factory authorized service personnel, so as to minimize the risk of possible ignition due to incorrect parts or improper service.
- **WARNING:** Risk of child entrapment and suffocation. Before you throw away this or an old unit, take off the door. Leave the shelves in place, so that children may not easily climb inside.

- SAVE THESE INSTRUCTIONS -

ELECTRICAL CONNECTION

	<p>Improper use of the grounded plug can result in the risk of electrical shock. If the power cord is damaged, frayed or shows cracks or abrasions across its length, have it replaced at an authorized service center.</p>
--	--

For your protection, this unit is equipped with a 3-conductor cord set that has a molded 3-prong grounding-type plug, and should be used in combination with a properly connected grounding-type outlet.

- Do not under any circumstances cut or remove the third ground prong from the power cord supplied. For personal safety, this appliance must be properly grounded.
- The cord should be secured behind the unit and not left exposed or dangling to prevent accidental injury.
- A standard electrical supply (115/120V AC only, 60Hz, 15A), properly grounded in accordance with the National Electrical Code and local codes and ordinances, is required.
- Never unplug the unit by pulling the power cord. To disconnect the appliance, always grip the plug firmly and pull straight out from the wall outlet. When moving the unit, be careful not to damage the power cord.
- The unit should always be plugged into its own individual electrical outlet with a voltage rating that matches the rating label on the unit.

Extension Cord

CAUTION: It is strongly recommended that you do not use an ad cord with this unit.

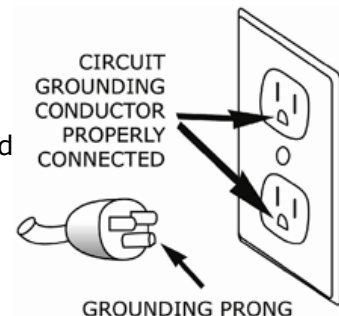

PARTS AND SPECIFICATIONS

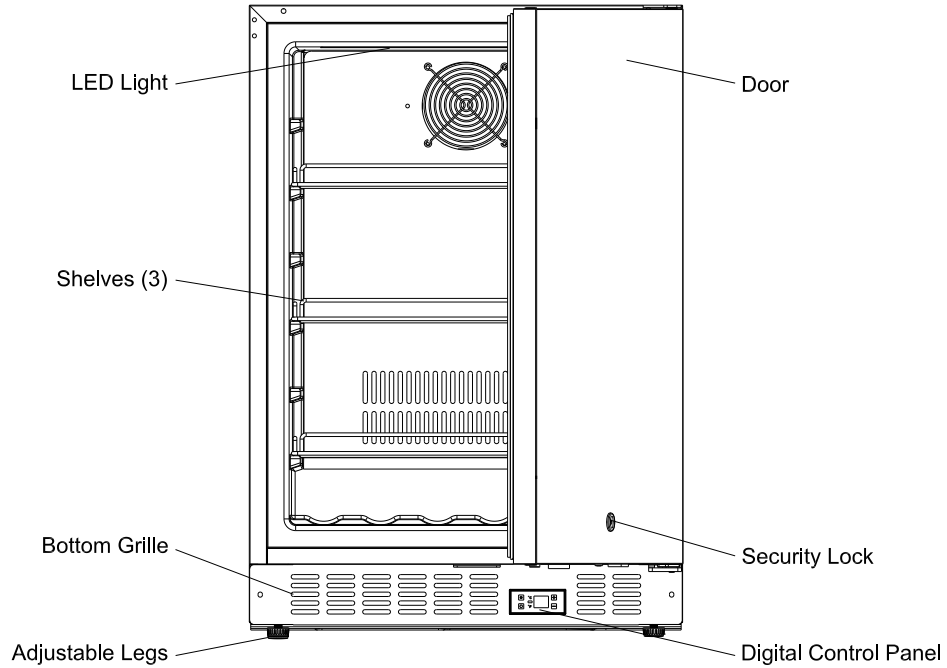

Model No.	VT-FZR240I
Voltage	AC 115V
Frequency	60 Hz
Ambient Temperature Range	44°- 106°F
Control Temperature Range	-11°- 11°F
Refrigerant	R600a/1.24oz
Power Consumption	390 kWh/Year
Input Power	100W
Volume	4.7 Cu.Ft.
Net Weight	93 lbs
Gross Weight	101 lbs
Dimensions (W x D x H)	23.4" x 23.4" x 34"
Box Dimensions (W x D x H)	26" x 26" x 36.5"

INSTALLATION

- Remove all packing material before using your appliance.
- **IMPORTANT:** Before connecting the unit to a power source, let it stand upright for approximately 24 hours. This will reduce the possibility of a malfunction in the cooling system from handling during transportation.
- Clean the interior surface with lukewarm water and a soft cloth.
- This unit is designed for freestanding or built in installation and indoor or outdoor use. Position the unit in a dry and well-ventilated place. Avoid placing the unit near any source of heat or moisture, or in direct sunlight. Do NOT install the unit in a location with an ambient temperature that will fall below 44°F.
- For freestanding installation, 5 inches of space between the back and sides of the unit are suggested, which allows the proper air circulation to cool the compressor and condenser for energy saving. Even for built-in installation, it is a must to keep ¼" space on each side and at the top to ensure proper service access and ventilation. And the air vent at the front of the appliance must never be covered or blocked in any way.
- Place the unit on a level surface strong enough to support it when it is fully loaded. To level the appliance, adjust the front leveling legs at the bottom of the appliance.
- For best performance it is recommended that you install the appliance in a location with an ambient temperature between 44°-106°F. If the ambient temperature is above or below recommended temperatures, the performance of the unit may be affected.

REVERSING THE DOOR SWING OF YOUR APPLIANCE

This unit has the capability of the door opening from either the left or right side. The unit is delivered to you with the door opening from the left side. Should you desire to reverse the opening direction, please follow the reversal instructions shown below.

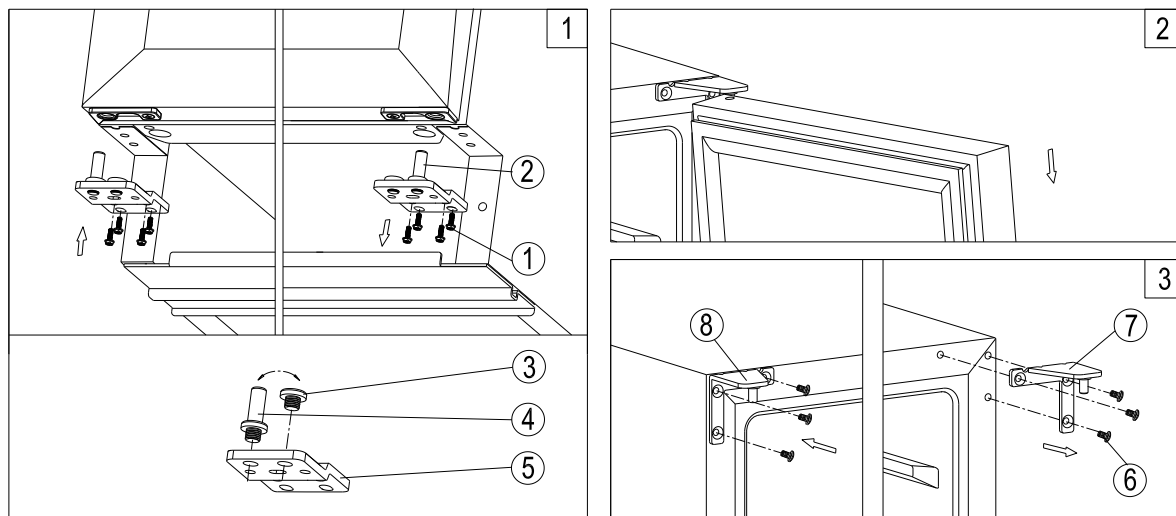

NOTE: All parts removed must be saved to allow the door swing to be reversed.

1. Remove the bottom hinge (2) by unscrewing the four lock screws (1). Be careful to hold the door firmly after removing the screws. (Fig. 1)

2. Gently pull down to remove the door from the right top hinge and place it on a padded surface to avoid the risk of damage. Then remove the right top hinge (7). (Fig. 2 & 3)
3. Unscrew and transfer pins (4) and (3) of the hinge plate to the opposite side. (Fig. 1)
4. Pop out the cover caps on the left side of the cabinet and use them to cover the screw holes on the right hand side.
5. Screw the alternative left top hinge (8), included in the fittings, on the left hand side of the cabinet. (Fig. 3)
6. Relocate the door to the designated position. Then screw the bottom hinge assembly on the left designated position and tighten it after the door is leveled. (Fig. 1)

OPERATING YOUR APPLIANCE

CONTROLS

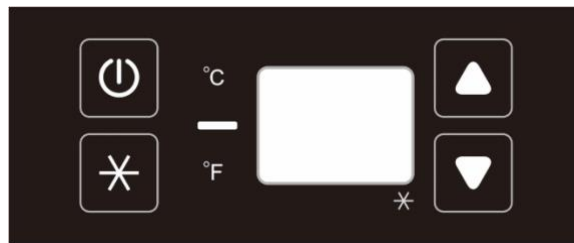

ON/OFF Power

To turn the appliance ON or OFF, press and hold the POWER key for 5 seconds.

NOTE: Pressing the POWER key once can switch off the audible alarm when the alarm is on.

SuperFreeze *

SuperFreeze is used to freeze fresh food quickly. The function overrides the thermostat control and will make the compressor operate continuously. It is not necessary to adjust the thermostat setting when using this function. When the function is selected, the SuperFreeze indicator (the dot at the bottom right of the display) will be ON. The function can be canceled by pressing the key again and the indicator will turn OFF. SuperFreeze will turn off automatically after 8 hours.

UP ↑

Used to increase (warm) the set temperature by 1°C/1°F.

DOWN ↓

Used to decrease (cool) the set temperature by 1°C/1°F.

°F/°C Selector

Select the temperature display setting in Fahrenheit or Celsius degree. To change the temperature from Fahrenheit to Celsius or from Celsius to Fahrenheit, press and hold the **SUPERFREEZE** key for 5 seconds.

SETTING THE TEMPERATURE

- You can set the temperature by pressing the **UP** and **DOWN** keys. When you press either of the two keys for the first time, the LED readout will show the original temperature set previously. (The temperature preset at the factory is 0°F, or -18°C.)
- The temperature you are setting will increase by one degree each time you press the **UP** key, and will decrease by one degree each time you press the **DOWN** key.
- The range of the temperature control is from -11°F to 11°F.
- To view the set temperature at any time, press the **UP** or **DOWN** key. The set temperature will flash in the display window for 5 seconds. After 5 seconds, the temperature inside the unit will reappear in the display window.

INTERIOR LIGHT

- The unit is fitted with an interior LED light system which will be turned ON when the door is open and it is designed for extremely long life. It is not user serviceable. To change the LED light fitting, please contact the service department.

NOTE: Please use only the same type of LED light fittings originally provided by the manufacturer.

NOTE: When using the unit for the first time or after a long period of inactivity, there may be a variance of a few degrees between the selected temperature and the temperature indicated on the LED readout. This is normal due to the length of inactivity, and will correct itself after the unit is run for a few hours. If the unit is unplugged, has lost power or is turned off, wait 3 to 5 minutes before restarting the unit. The unit will not restart before this time delay.

SABBATH MODE

Sabbath mode is available for the observance of certain religious holidays. This mode turns off the displays, interior light and audible alarms and prevents them from turning on again. Normal cooling operations will still take place.

To initiate Sabbath mode, press the **POWER** and **SUPERFREEZE** keys at the same time for at least 5 seconds. The indicator light (the dot at the bottom right of the display) will flash four times and confirm the Sabbath mode is ON. Sabbath mode can be canceled by repeating the above process. The Sabbath Mode will automatically turn off after 96 hours.

TEMPERATURE MEMORY FUNCTION

- In the event of a power interruption (power surge, breaker switch, etc.), the unit can remember the previous temperature settings, and when the power is recovered, the cabinet temperature will return to the same setting temperature as before the power went off.

TEMPERATURE ALARM / DOOR ALARM

- An audible alarm sounds if the storage temperature is not cold enough. The temperature display flashes at the same time.

- The cause of the temperature being too high may be:
 - Warm fresh food was placed inside
 - Too much warm ambient air flowed in when rearranging and removing food
 - Power failure for some time
 - The appliance is faulty
- The audible alarm is automatically silenced and the temperature display stops flashing when the temperature is sufficiently cold again.
- If the door has been left open for more than 60 seconds, the alarm will sound. Pressing the POWER key once can switch off the audible alarm.

SHELVES

To avoid damaging the door gasket, ensure that the door is fully opened when pulling the shelves out of the rail compartment.

- Any of the shelves can be removed to store larger items.
- When removing the shelf out of the rail compartment, make sure to remove all items first. Then move the shelf to the position where the notch of the shelf is exactly under the plastic post and lift the shelf. In order to replace the shelf, repeat steps described above in reverse.

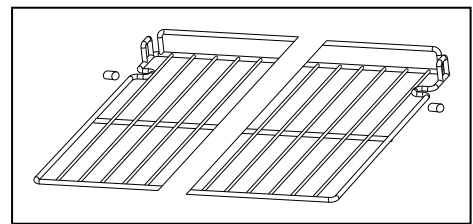

DOOR LOCK

The freezer comes with a lock and key combination. The keys are located inside the plastic bag containing the Owner's Manual. To unlock the door, insert the key into the lock and turn it counter-clockwise. To lock the door, insert the key and turn it clockwise, ensuring that the metal pin is fully engaged.

DEFROSTING

- The unit defrosts automatically in normal operating conditions.
- The evaporator behind the rear wall of the unit defrosts automatically. The condensate collects in the drainage channel behind the rear wall of the unit, and flows through the drainage hole into the drip tray by the compressor where it evaporates.

USING THE FREEZER

- The freezer is designed for the long-term storage of frozen food. Storage time is up to three months.
- The storage life of frozen foods varies and the recommended storage time should not be exceeded.
- Pre-packaged commercially frozen food should be stored in accordance with the frozen foods manufacturer's instructions for a three star frozen food storage compartment or home freezer.
- Place frozen food into the freezer as quickly as possible after purchase. If there are instructions on the packet, carefully follow these instructions regarding storage times.

CARE AND MAINTENANCE

CLEANING YOUR APPLIANCE

IMPORTANT: Always unplug the unit before cleaning or performing maintenance. Never use harsh cleansers or scouring pads to clean any part of the unit.

- Turn off the power, unplug the appliance, and remove all items including shelves.
- Wash the inside surfaces with a warm water and baking soda solution. The solution should be about 2 tablespoons of baking soda to a quart of water.
- Wash the shelves with a mild detergent solution.
- Wring excess water out of the sponge or cloth before cleaning control panels or any electrical parts.
- Wash the outside cabinet with warm water and mild liquid detergent. Rinse well and wipe dry with a clean soft cloth.
- Use an approved stainless steel cleaner to clean the door. Do not use steel wool or a steel brush on the stainless steel.

POWER FAILURE

Most power failures are corrected within a few hours and should not affect the temperature of your appliance. If the power is off for an extended period of time, proper steps should be taken to protect your contents.

INACTIVITY

If the unit will not be used for a period of less than three weeks, leave the unit operating. If the period of inactivity is several months, remove all items and turn the unit off. Clean and dry the interior thoroughly. Leave the door open slightly to prevent any possible moisture build-up.

MOVING YOUR APPLIANCE

Before moving your unit, first be sure to remove all items from the unit.

- Securely tape down any loose items, such as shelves, inside the unit.
- Turn the adjustable leg up to the base to avoid damage.
- Tape the door shut.
- Ensure that the unit stays securely in the upright position during transportation. Protect the outside of the appliance with a blanket or similar item.

ENERGY SAVING TIPS

- The appliance should be located in the coolest area of the room or outdoor location, away from heat producing appliances and out of direct sunlight.
- Ensure that the unit is adequately ventilated. Never cover air vents.
- Do not keep the door open any longer than necessary.
- Let hot foods cool to room temperature before placing in the unit. Overloading the unit forces the compressor to run longer.
- Be sure to wrap foods properly, and wipe containers dry before placing them in the unit. This cuts down on frost build-up inside the unit.
- Unit shelves and storage bins should not be lined with aluminum foil, wax paper, or paper towels. Liners interfere with cold air circulation, making the unit less efficient.

- Organize and label food to reduce door openings and extended searches. Remove as many items as needed at one time, and close the door as soon as possible.



CAUTION: Failure to unplug the appliance could result in electrical shock or personal injury.

PROBLEMS WITH YOUR APPLIANCE

Most common problems can be solved easily, saving you the cost of a possible service call. Try the following suggestions to see if you can solve the problem before contacting Vinotemp at info@vinotemp.com.

TROUBLESHOOTING

PROBLEM	POSSIBLE CAUSE	REMEDY
Appliance does not operate.	<ul style="list-style-type: none"> • Appliance is not connected to a power supply. • The appliance is turned off. • Tripped circuit breaker or a blown fuse. 	<ul style="list-style-type: none"> • Connect the appliance. • Switch on the appliance. • Switch on circuit breaker or replace fuse.
Appliance is not cold enough.	<ul style="list-style-type: none"> • The temperature is not set correctly. • The ambient temperature could require a lower temperature setting. • The door was opened too often. • The door was not closed completely. • Door does not create an airtight seal. • The condenser is too dirty. • The ventilation opening is blocked or too dusty. 	<ul style="list-style-type: none"> • Check the set temperature. • Set a lower temperature. • Do not open the door more often than necessary. • Close door properly. • Check the door seal and clean or replace. • Clean the condenser when necessary. • Clear the obstructions and clean the dust.
Appliance turns itself on and off frequently.	<ul style="list-style-type: none"> • The room temperature is higher than average. • A large amount of food has been added to the unit. • The door is open too often. • The door is not closed completely. • The door gasket does not seal properly. 	<ul style="list-style-type: none"> • Put the appliance in a cooler place. • Leave the appliance to work for a while until the set temperature has been reached. • Do not open the door more often than necessary. • Close door properly. • Check the door seal and clean or replace.
The light does not work.	<ul style="list-style-type: none"> • Appliance is not connected to a power supply. • Tripped circuit breaker or a blown fuse. • The light was switched off on the control panel. 	<ul style="list-style-type: none"> • Connect the appliance. • Switch on circuit breaker or replace fuse. • Switch on the light.
Vibrations	<ul style="list-style-type: none"> • The appliance is not properly level. 	<ul style="list-style-type: none"> • Level the appliance with the adjustable feet.
The appliance seems to make too much noise.	<ul style="list-style-type: none"> • There is a rattling noise. • There are gurgling sounds. • There are popping and cracking noises. 	<ul style="list-style-type: none"> • This noise may be caused by the internal flow of the refrigerant. This is normal. • As each cycle ends, these sounds may be caused by the flow of refrigerant in the appliance. • These sounds are usually caused by internal temperature

	<ul style="list-style-type: none"> • The appliance is not properly leveled. 	<p>fluctuations. It is due to the contraction and expansion of the interior walls.</p> <ul style="list-style-type: none"> • Level the appliance with the adjustable feet.
The door will not close properly.	<ul style="list-style-type: none"> • The appliance is not properly level. • The door was reversed and not properly installed. • The gasket is dirty. • The shelves are out of position. 	<ul style="list-style-type: none"> • Level the appliance with the adjustable feet. • Check the door hinge and reassemble correctly. • Clean the door gasket. • Check the shelves and refit correctly.
Display "E1", "E2" or "E7".	<ul style="list-style-type: none"> • "E1" or "E2" indicates the air temperature sensor has failed. • "E7" indicates a door switch failure. 	<ul style="list-style-type: none"> • Call for service.
The alarm sounds and the temperature display flashes.	<p>Has the appliance door been open for longer than 60 seconds? If not, then the temperature has risen higher or fallen lower than the temperature that has been set. This could be due to:</p> <ul style="list-style-type: none"> • The appliance door being opened too often. • The ventilation opening being covered or too dusty. • A lengthy interruption to the power supply. • A large amount of bottles has been added to the unit. 	<p>If yes, close the door.</p> <ul style="list-style-type: none"> • Do not open the door more often than necessary. • Clear the obstructions and clean the dust. • Leave the appliance to work for a while until the set temperature has been reached.
The icon "--" is lit and flashing in the temperature display.	<ul style="list-style-type: none"> • The display temperature is out of range. 	<ul style="list-style-type: none"> • Only temperatures within the range 0~99°F/-9~37°C can be displayed. If the temperature is not within this range, the icon "--" will be displayed instead. This is normal.

TERMS OF SALE AND WARRANTY

Vinotemp International Corp. ("Seller") and the person or entity that acquires these goods from Seller ("Purchaser") hereby fully agree to the following terms and conditions of the sale: **Shipping** fees are the responsibility of the Purchaser whether freight prepaid or freight collect. Seller assumes responsibility for the goods sold to the Purchaser until the goods have reached Purchaser's delivery address (FOB Destination) and the delivery receipt is signed clear. Seller is not responsible for the carrier's late delivery, missed delivery, unpaved roads, remote locations, stairs, elevators, narrow door openings and other such issues in attempting to fit or deliver the goods into the Purchaser's location. Delivery to remote locations may require additional fees. Remote location may be defined at the discretion of the carrier as more or less than 50 miles from the nearest major city. Purchaser assumes all responsibility for additional costs related to freight such as access, measurement, installation, hookup, wiring, moving and storage of the goods, flight of stairs, carrier's inability to safely and/or adequately deliver, inability to use the building elevator to lift the goods, narrow openings, along with any additional costs to deliver or redeliver the product properly. Make sure to review access to the property and size of the product ordered. The transportation of all goods is subject to the terms and conditions which the carrier imposes on Purchaser. Installation is the responsibility of the Purchaser. If white glove delivery was ordered and cannot be performed properly, or access is hindered in any way, Purchaser agrees to accept delivery curbside (delivery service cannot be refunded). If Purchaser will-calls or pays for their own freight responsibility transfers to the Purchaser when the Purchaser or Purchasers freight company picks up the unit from Seller. Freight quoted are either curbside, threshold or white glove. Standard white glove delivery is main floor, easy access and NO STAIRS, Doors, aligned feet attached (if necessary) and removal of packaging, additional fees for additional requests. Each service has a different rate and will require additional fees. If freight is not charged (Free Shipping or Freight Included) and the order is cancelled after shipping, a freight charge of 25% of the cost of the unit, each direction will be charged. Item swap outs are arranged as curbside delivery and pickup unless noted otherwise. There is no white glove service for returns. Approved returns must have original and/or proper packaging. Swapouts (Delivery and Pick up are at the same time) Original unit must be packed and ready for carrier pick up at time of delivery of new unit. Packaging of old unit must be adequate for shipping, not oversized or on a pallet if unit was not originally delivered on a pallet. Carrier will not drop off new unit if the original unit is not ready. If the carrier has to make a second attempt, customer will be subject to additional charges for the attempted delivery and for any packaging issues. Deliveries include ONE attempt by the shipping company to deliver the product to the consumer. If for any reason the customer is unavailable to accept the order and the product is undeliverable under any circumstances, the customer will be responsible for any extra shipping and handling charges. We are a manufacturer not a shipping company, deliveries are done by a third party service. Email us at info@vinotemp.com for a quote or any additional information. Freight discussed is Continental USA (excluding Alaska, Puerto Rico, Hawaii), cost is additional please email info@vinotemp.com for a quote.

California **Proposition 65** Warning: The products sold on this ecommerce website and to the public may contain chemicals and other substances known to the State of California to cause cancer and birth defects and other reproductive harm. Totes made of vinyl, imitation leather, and/or leather material contain lead and/or other substances that are known to the State of California to cause cancer, birth defects and other reproductive harm. Galvanized metal and some of its constituents contain lead and/or other substances that are known to the State of California to cause cancer, birth defects and other reproductive harm. Products made of vinyl contain lead, Diethyl Hexyl Phthalate (DEHP), and/or other substances that are known to the State of California to cause cancer, birth defects and other reproductive harm. Acrylic may contain Acrylic Acid and/or other substances that are known to the State of California to cause cancer, birth defects, and other reproductive harm. Appliances may contain tin or lead in either the paint or the controllers, and/or other substances that are known to the State of California to cause cancer, birth defects, and other reproductive harm. Our barware items may contain plastic, acrylic, enamel, crystal, metal and/or other substances that are known to the State of California to cause cancer, birth defects, and other reproductive harm. Appliances may contain Tin, Lead or Nickel.

Damage: All damages must be noted at time of delivery. If a bill is signed that there is no damage, buyer accepts delivery as free and clear. Any claim for damages of the goods, when FOB Destination, that incurred during shipment by the carrier are insured and handled directly with the carrier by the Seller if noted on the receipt and notified within 48 hours of delivery. **OPEN AND INSPECT YOUR DELIVERY.** When FOB Destination, if the item is damaged by the freight company, and Purchaser cancels rather than accepts a replacement, the order can be cancelled by paying for freight costs both ways and a 35% restocking fee for stocked items. No cancellation or refunds on custom/made or made to order products. When shipped 3rd Party (FOB Warehouse), Purchaser assumes all responsibility for delivery, payment of freight and freight claims for damages during shipment. Manufacture defects will be handled directly with Seller, subject to the limited warranty below.

Fees: All sales are final. Unless authorized in writing by the Seller, Purchaser may not return the goods under any circumstance. If Seller agrees in writing to take back stocked goods, there will be a restocking/service fee that is 35% of the purchase price of the goods and freight both ways (product must be new, unused, and in original packaging). If Purchaser returns goods claiming that the goods are defective and goods are found to be in working condition by the Seller, Purchaser is liable for the cost of freight both ways plus and a service fee that is 35% of the purchase price of the goods. Built to Order and Custom products are nonreturnable, nonrefundable. Purchaser must notify Seller of nonconforming goods within 48 hours of receipt, after which time all goods are deemed accepted by the Purchaser. If an order has been placed and production has not started, cancellation of your order will be a 15% charge. If Purchaser tenders payment with a check that has insufficient funds (NSF), a collection fee plus NSF fee of \$50 will be added to the invoice, which Purchaser agrees to pay promptly. If Purchaser puts a stop payment on a check or credit card for any reason, Purchaser agrees to pay for all costs associated with the Seller's collection or litigation of such a claim, including, without limitation, general and special damages, court costs and attorneys' fees. Finance charges begin the date of invoice. Title to the goods reverts back to the Seller in the case of nonpayment of goods or services. All fees and costs to retrieve the product, cost of freight, legal costs, collection fees and court fees, credit card fees and interest rate of 18%



(annual rate) will be the responsibility of the Purchaser. In a credit card dispute, Purchaser assumes and must immediately pay any "credit card arbitration" fees and chargeback fees which the credit card companies charge at the time of the chargeback. Canceled orders using a Credit Card will have an additional fee of 3% deducted from the refund. Any disputes not resolved within 30 days from the invoice date will be reported to credit reporting agencies.

LIMITED WARRANTY: Seller warrants that the goods will be free of defects in materials and workmanship as follows:

Furniture style (wood) wine cabinets made in the U.S.: all cooling unit parts only for a period of 5 (five) years; cabinetry and labor (uninstalled) for a period of 12 (twelve) Months (Model numbers "Vino" and "Custom".

Metal cabinet units (appliances) (compressor) (made in China and Denmark) (Model numbers start with EL, VT, IL, or EP: parts and labor for cooling system and cabinetry for a period of 12 (twelve) months.

Thermoelectric Units: 90 (ninety) days (including Wine and Beverage Coolers, Beer Dispensers, Humidor, Portofino Wood Cellars, and Refrigerators). (Models start with EL, VT, IL or EP). WineMate and Cellar Tec (WM, Wine Mate or CT) (Wine Cooling Units) Split and Ducted Systems and other installed cooling units are parts only for 1 year, no labor. Self Contained WineMate Cooling Systems are 5 years parts, 1year labor. Removal and reinstallation of cooling units is not included.

Wine Accessories, Racking Systems, Parts and Other miscellaneous items is a 30 day warranty.

Il Romanzo units: Warranty 90 (ninety) days. Replacement part 12 (twelve) months from the date of sale.

Non-New Units (Scratch & Dent/Refurbished/Floor Models), warranty for compressor units is 90 days from your dated invoice and 30 days for thermoelectric units (parts for function only, not cosmetic defects). These units are refurbished and sold as is; Purchaser assumes risks to the quality and performance of goods and assumes the costs of all necessary service or repair not covered herein. Extended warranties via New Leaf may not be purchased on Non-New Units. Delivery is curbside. Upgrades in delivery will require an additional fee.

Element Grills (via Element Products LLC), grills have a thirty day limited parts warranty on grill accessories.

If a model is not listed here will have 90 day warranty on parts only if it's a new item.

Parts and Repairs:

Warranty on in-house repairs: 90 days parts and labor for compressor; 30 days parts and labor for Thermoelectric; Customer is required to put down a labor deposit of \$75 for Thermoelectric units; \$150 for compressor based Wine Coolers and \$195 for WineMate units which will be kept if a unit is found to be in good working condition. Customer is responsible for freight costs to us.

Warranty on parts purchased: 30 days; if part fails within 30 days of purchase, customer is to ship us back the part; upon inspection, if defective, VT will send replacement part at no charge.

If a purchaser claims a product is "defective" with regards to refrigeration, Purchaser must obtain a letter from a qualified refrigeration technician at the Purchaser's cost to verify that the unit was installed properly, with proper ventilation and the unit is truly malfunctioning due to a manufacturing defect.

Removal or reinstallation of a unit is not included in warranted costs. Purchaser's exclusive remedy is limited at Seller's option to repair or replace defective part[s] with either new or reconditioned part[s]. Purchaser is responsible for shipping the unit prepaid to a designated facility and Seller will pay return shipping charges in the continental United States for items repaired under warranty within 12 (twelve) months from date of sale. The returned unit must be packaged correctly, with enough protection to ensure the unit is not further damaged. Oversized or lack of packaging is not permitted and will be refused. Replacement or exchanged units will be returned to Purchaser through curbside delivery only. Any redelivery fees are the Purchaser's responsibility. Since the natural variation in texture, density, grain, color, tone, and shade of wood is unavoidable; Seller does not guarantee the texture, color, tone, or shade of the wood: nor does seller guarantee the colorfastness of wood or against peeling, chipping, cracking, or scratching. Note: Unfinished wood is subject to warping; all wood surfaces must be sealed before placing cellar into service. Make sure doors are aligned by reviewing the owner's manual. Improper repair or placement of the unit will void the warranty. Any third party repair facility must be preapproved in writing by Seller, before providing replacement parts under warranty. Change Orders: Custom units already in production that require a change will be subject to a change order fee.

Storage Fees: When having an item serviced by a Vinotemp service technician at the Vinotemp facility, Purchaser agrees to pick up their repaired item or make arrangements for return shipping within a 60day period once they have been notified by Vinotemp through phone call, email, or letter that their unit is ready for pick up. If the item remains in the Vinotemp warehouse after 60 days but no longer than 120 days, the Purchaser will incur additional storage fees of 2%. After 120 days in storage, the item will become property of Vinotemp. Warranty period is from the date of sale (not from shipping, delivery, nor installation). All completed cabinetry, racking, or other custom work must be picked up or shipped within a period of 14 days after Vinotemp has notified the Purchaser by phone call, email, or letter. Any completed cabinetry, racking, or other custom work stored longer than 14 days will incur an additional storage fee. After 120 days, the product will become property of Vinotemp.

This Limited Warranty does not cover damage due to such things as accident, misuse, abuse, mishandling, neglect, acts of God, fires, earthquakes, floods, high winds, government, war, riot or labor trouble, strikes, lockouts, delay of carrier, unauthorized repair, or any other cause beyond the control of the Seller, whether similar or dissimilar to the foregoing. Seller is not responsible for any damages caused to Purchaser's property resulting from the goods. This limited warranty applies only inside the Continental US (Alaska, Puerto Rico, Hawaii and other territories/countries are not warranted). Purchaser understands and acknowledges that the goods sold here are wine cellars, cigar humidors, and/or other similar units which house wine or cigars or other items. Purchaser assumes all risk of using these units, including risk of spoilage, humidity variations, temperature variations, leaks, fire, water damage, mold, mildew, dryness and similar and any other perils that might occur. Seller is not responsible for incidental or consequential damages, and there are no warranties, expressed or implied, which extend beyond the Limited Warranty described above. Warranty and liability are nontransferable. The implied warranties of merchantability and of fitness for a particular purpose are hereby expressly disclaimed. Some states do not allow the exclusion of incidental or consequential damages, or a waiver of the implied warranties of fitness and/or merchantability, so the above limitations may not apply to you. This warranty gives you specific legal rights and you may also have other rights which vary from state to state. Seller disclaims any indemnification for claims of infringement of any intellectual property of protectable nature. In the event of

any dispute between Seller and Purchaser arising out of or relating to these terms and conditions or to the goods sold generally, Purchaser must first file a written claim with Seller within ten days of the occurrence giving rise to the claim and wait an additional thirty days for a response before initiating any legal action. The sale and all terms are subject to California law. Any legal proceeding arising out of or relating to these terms and conditions or to the goods sold Purchaser shall bring, solely and exclusively in the County of Los Angeles. In no event may Purchaser initiate any legal proceeding more than six months after the occurrence of the event giving rise to the dispute. Seller may make nonpayment claims until debt is paid in full. Any dispute or claim relating in any way to these to the Terms and Conditions, the Website, or any products or services sold or distributed by or through this Website, store, or catalog will be resolved by binding arbitration, rather than in court, except that you may assert claims in small claims court if your claims qualify. The Federal Arbitration Act and federal arbitration law apply to the Terms and Conditions. We each agree that any dispute resolution proceedings will be conducted only on an individual basis and not in a class, consolidated or representative action. If for any reason a claim proceeds in court rather than in arbitration we each waive any right to a jury trial. Both parties agree to bring suit in court to enjoin infringement or other misuse of intellectual property rights.

The above terms and conditions are the only ones governing this transaction and Seller makes no oral representations of any kind. These Terms and Conditions can only be modified in writing, signed by both Purchaser and Seller.
12/17



SERVICE & IMPORTANT NOTICE

Upon receipt and inspection of unit, the supply cord must be replaced if it is damaged. Contact our customer service at 1-800-777-8466 or info@vinotemp.com.

The manufacturer has a policy of continuous improvement on its products and reserves the right to change materials and specifications without notice.

WARNING:
Please do not place the unit within reach of children.
For adult use only.

Contact info@vinotemp.com with any questions or visit
www.vinotemp.com

Vinotemp[®]

732 South Racetrack Road
Henderson, NV 89015
www.vinotemp.com

Vinotemp is a registered trademark of Vinotemp International. All products, features, and services are subject to change without notice. We cannot guarantee the accuracy of the contents of this document. We disclaim liability for errors, omissions, or future changes.

© 2019 Vinotemp International. All rights reserved.

