

# Vinotemp®

A PROUD HERITAGE OF EXPERIENCE & QUALITY



**WINE BOTTLE  
CHILLER/WARMER  
VT-CHILLER SLVR**

**OWNER'S MANUAL**

*Vinotemp®*

[WWW.VINOTEMP.COM](http://WWW.VINOTEMP.COM)



Thank you for purchasing this Wine Bottle Chiller/Warmer. Before use, please read the safety instructions and precautions contained in this manual to ensure the safe use of this product.

## **KEY FEATURES**

The Wine Bottle Chiller/Warmer uses Peltier and CPU technology to control 10 temperature settings (min, 37°F, 43°F, 48°F, 54°F, 59°F, 64°F, 70°F, 75°F, and 122°F) designed for cooling, warming and keeping constant temperature for various kinds of wines (such as white wines, red wines, Japanese sake, etc.). Very easy to control the wine at optimum temperature

## **SPECIFICATIONS**

- Aluminum container: 3.5 inches diameter
- Temperature settings: 10 settings (min, 37°F, 43°F, 48°F, 54°F, 59°F, 64°F, 70°F, 75°F, and 122°F)
- Fan: 3.5" x 3.5" Brushless motor
- High pressure protection: 122°F
- Power supply: 12V DC, 5 Amp
- Power consumption: 60 W
- Dimensions: 8.425" x 6" x 8.22" (HxWxD)

## PARTS

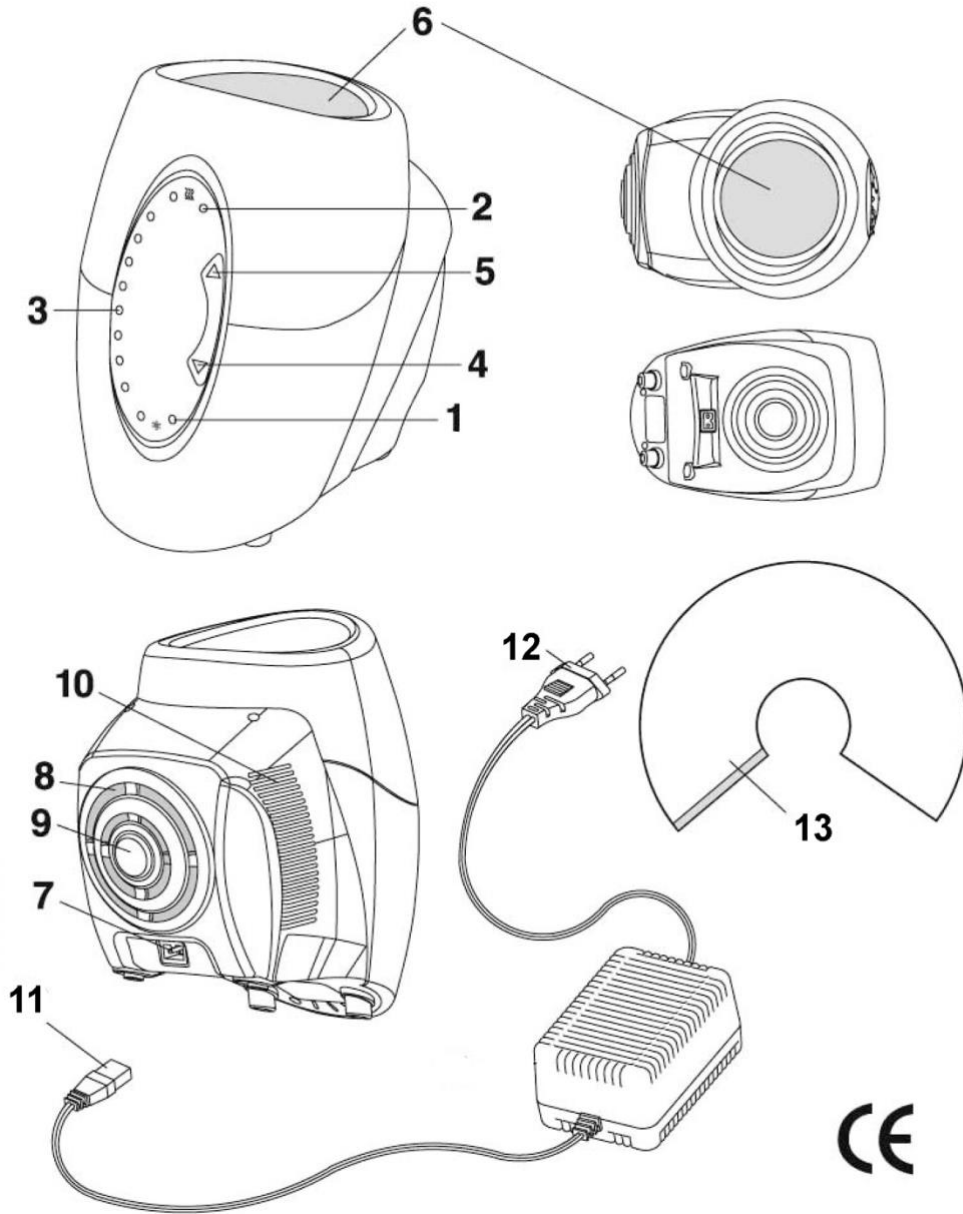

- |   |                            |
|---|----------------------------|
| 1. Blue "Cooling" LED light                             | 7. Power cord input socket |
| 2. Red "Warming" LED light                              | 8. Air inlet for fan       |
| 3. 10 green LED lights to indicate selected temperature | 9. Removable air filter    |
| 4. "Down" button to decrease the temperature setting.   | 10. Air outlet             |
| 5. "Up" button to increase the temperature setting.     | 11. Unit input plug        |
| 6. Aluminum container with 3 ½" diameter (90mm).        | 12. Wall outlet plug       |
|   | 13. Insulation sleeve      |

**Important:** To avoid electric shock, do not open the unit. Any repair work must be done by a qualified technician. Specifications are subject to change for improvement without prior notice.

## CONNECTION

1. After removing the packing materials, there should be three items:
  - a. Wine Bottle Chiller/Warmer unit
  - b. Power supply cord
  - c. Insulation sleeve
2. Plug the Unit Input Plug from the power supply cord into the Input Plug Socket located on the back of the unit. Then connect the Wall Outlet Plug into the nearest wall outlet. The default temperature is set is "min" and the blue LED light on the control panel will turn on after 5 seconds.

## OPERATING INSTRUCTIONS

You may press the "Up" button (fig. 1) or the "Down" button (fig. 2), located on the front of the unit, to select your desired temperature. The 10 green LED indicating lights will show your temperature selection. The sensors inside the unit detect the temperature of the aluminum container and the CPU will compare the set temperature to decide whether the unit should be "cooling" or "warming."

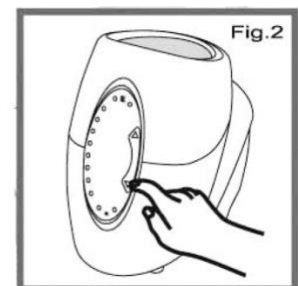
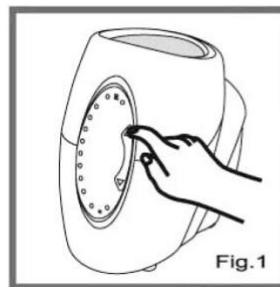

"Cooling" – If the temperature of the aluminum container is higher than the set temperature set, the blue "Cooling" LED light, located on the front of the unit, will be on (fig. 3).

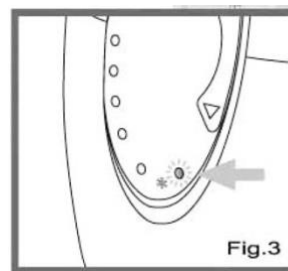

"Warming" – If the temperature of the aluminum container is lower than the set temperature, the red "Warming" LED, located on the front of the unit, will be on (fig. 4).

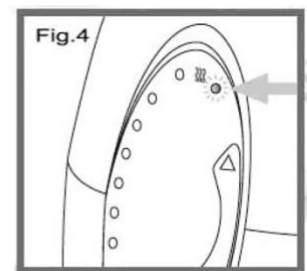

When the temperature of the aluminum container has reached the set temperature, the blue and red LED lights on the control panel will both turn off – leaving only the green LED light that indicates the set temperature will be on.

It takes the sensor 5 seconds to switch from warming to cooling mode, and vice versa.

The main function of this unit is not only to "cool" or "warm" the wine bottle but also in maintaining the temperature. Please note that white wine that has been chilled in the refrigerator before placing it in the Chiller/Warmer will shorten the chilling time in the unit, Otherwise it will take 1 hour to cool.

For faster cooling or warming, the insulation sleeve provided may be used to cover the top part of the bottle.

For wine bottles that are smaller than 3.5 inches, we recommend the bottle be placed off center so that the bottle can be in contact with the wall of aluminum container for effective cooling. The shape of the insulation sleeve can be altered.

## CLEANING THE FILTER

You may remove the Air Filter from the bottom of the unit for cleaning or washing (fig. 6). Before removing the air filter, be sure to disconnect the unit from the wall outlet.

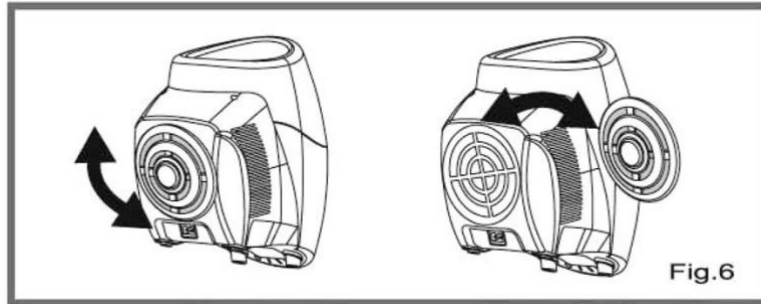

## PRECAUTIONS

- Do not put ice or water inside aluminum container.
- After having finished using the Wine Bottle Chiller/Warmer, disconnect the unit from the wall outlet.
- Avoid using the power cord in wet or damp areas.
- Avoid putting any paper, plastic bag, or cloth to cover the back of the unit that will block the air vent.
- If there is more than one green LED light that is on at the same time, please unplug the power cord from the unit and plug it back in again.
- If there is no power coming from the power cord, it should be checked by a qualified electrician to see if the fuse inside is working properly.

# TERMS OF SALE & WARRANTY

Vinotemp International ("Seller") and the person or entity that acquires these goods from Seller ("Purchaser") hereby fully agree to the following terms and conditions of the sale: Shipping fees are the responsibility of the Purchaser whether freight prepaid or freight collect. Seller assumes no responsibility for the goods sold to the Purchaser once the goods have left the Seller's premises, including, but not limited to, late delivery by the moving carrier, or for events caused by any difficulty carrier incurs in attempting to fit the goods into the Purchaser's place of business or residence due to the size of the goods or otherwise. Purchaser assumes all responsibility for delivery, payment of freight, access, measurement, installation, hook-up, wiring, moving and storage of the goods. The transportation of all goods is subject to the terms and conditions which the moving carrier imposes on Purchaser including, but not limited to, additional charges imposed per flight of stairs, and/or additional charges resulting from the carrier's inability to safely and/or adequately use the building elevator to lift the goods to an upper floor. Any claim for damages incurred during shipment by the carrier of the goods are insured and handled directly with the carrier and must be noted at time of delivery. Any damages due to manufacture defects will be handled directly with Vinotemp International, subject to the limited warranty.

All sales are final, and unless authorized in writing by the Seller, Purchaser may not return the goods, under any circumstance. If Purchaser refuses to accept the goods, under any circumstance, the Purchaser is liable for the return and cost of freight both ways, and if Seller does take back the goods, there will be a restocking/service fee that is 35% of the purchase price of the goods. (Product must be in original packaging). Built-to-Order products (including Cabinets, Racking, and Accessories) are non-returnable. Purchaser must notify Seller of non-conforming goods within four days of delivery, after which time all goods are deemed accepted. If an order has been placed and production has started, cancellation of your order will be a 15% charge. If Purchaser tenders payment with a check that has insufficient funds (NSF), or stops payment on a check or credit card for any reason, Purchaser agrees to pay for all costs associated with the Seller's collection or litigation of such a claim, including without limitation extra damages, court costs and attorneys' fees. Finance charges begin the date of invoice. Collection fees plus NSF fee of \$50 will be added to your invoice, which you agree to promptly pay. Title to the goods does not pass until payment is received in full by Seller and Seller retains a security interest in the goods until they are paid for in full. Statute of limitations must be handled in arbitration in the County of Los Angeles.

**LIMITED WARRANTY:** Seller warrants that the goods will be free of defects in materials and workmanship as follows: Furniture style (wood) wine cabinets made in the U.S.: all cooling unit parts for a period of 5 (five) years; cabinetry and labor (uninstalled) for a period of 12 (twelve) months from date of sale. For the metal cabinet wine units: parts and labor for cooling system and cabinetry for a period of 12 (twelve) months from date of sale. Thermoelectric Units: 90 (ninety) days from the date of sale (including Wine Coolers, Beer Dispensers, Humidor, Portofino Wood Cellars, and Refrigerators). Wine-Mate Split Systems and installed products are parts only for 1 year, no labor. Other Wine-Mate Cooling Systems are 5 years parts, 1 year labor. Wine Accessories and Racking Systems are not warranted. There is no warranty on parts purchased separately. Removal and re-installation of unit is not included in warranted labor. Purchaser's exclusive remedy is limited, at Seller's option; to repair or replace defective part[s] with either new or factory reconditioned part[s]. Purchaser is responsible for shipping the unit pre-paid to designated facility and Seller will pay return shipping charges in the continental United States for items repaired under warranty within 12 (twelve) months from date of sale. Since the natural variation in texture, density, grain, color, tone and shade of wood is unavoidable; Seller does not guarantee the texture, color, tone or shade of the wood; nor does seller guarantee the colorfastness of wood or against peeling, chipping, cracking or scratching. Note: Unfinished wood is subject to warping; all wood surfaces must be sealed before placing cellar into service. Improper placement of the unit will void the warranty. By Vinotemp in writing, any third party repair facility must be pre-approved before providing parts free of charge. This limited warranty does not cover damage due to such things as accident, misuse, abuse, mishandling, neglect, acts of God, fires, earthquakes, floods, high winds, government, war, riot or labor trouble, strikes, lockouts, delay of carrier, unauthorized repair, or any other cause beyond the control of the Seller, whether similar or dissimilar to the foregoing. Seller is not responsible for any damages caused to Purchaser's property resulting from the good. This limited warranty applies only inside the Continental US. (Alaska, Puerto Rico and Hawaii are not warranted.)

For Non-New Units (Scratch & Dent/Refurbished/Floor Models), warranty for compressor units is 90 days from your dated invoice and 30 days for thermoelectric units (parts for function only, not cosmetic defects). These units are refurbished and sold as is; Purchaser assumes risks to the quality and performance of goods and assumes the costs of all necessary service or repair not covered herein.

For Element Grills (via Element Products LLC), grills have a 1 year comprehensive parts warranty on entire product. Three years limited parts warranty covering the stainless burner and a thirty day limited parts warranty on grill accessories. If grill is defective and unused plus all packaging and parts are intact, we will either replace the grill or provide service to repair the grill. Returned product must accompany all original packaging and parts and is subject to our 35% restocking fee (and freight both ways). With Wine-Mate products, if the customer calls and the product is "defective", you must obtain a letter from your qualified refrigeration technician at the customer's cost, to verify that the unit was installed properly, with proper ventilation and the unit is truly malfunctioning due to manufacture defect.

Purchaser understands and acknowledges that the goods sold here are wine cellars, cigar humidors, and/or other similar units which house wine or cigars. Purchaser assumes all risk of using these units, including risk of spoilage, humidity variations, temperature variations, leaks, fire, water damage, mold, mildew, dryness and similar and any other perils that might occur. Seller is not responsible for incidental or consequential damages, and there are no warranties, expressed or implied, which extend beyond the Limited Warranty described above. Warranty and liability are non-transferable. The implied warranties of merchantability and of fitness for a particular purpose are hereby expressly disclaimed. Some states do not allow the exclusion of incidental or consequential damages, or a waiver of the implied warranties of fitness and/or merchantability, so the above limitations may not apply to you. This warranty gives you specific legal rights and you may also have other rights which vary from state to state. Seller disclaims any indemnification for claims of infringement of any intellectual property of protectable nature. In the event of any dispute between Seller and Purchaser arising out of or relating to these terms and conditions or to the goods sold generally, Purchaser must first file a written claim with Seller within ten days of the occurrence giving rise to the claim and wait an additional thirty days for a response before initiating any legal action. The sale and all terms are subject to California law. Any legal proceeding arising out of or relating to these terms and conditions or to the goods sold generally shall be brought solely and exclusively in the County of Los Angeles. In no event may Purchaser initiate any legal proceeding more than six months after the occurrence of the event giving rise to the dispute.

The above terms and conditions are the only ones governing this transaction and Seller makes no oral representations of any kind. These Terms and Conditions can only be modified in writing, signed by both Purchaser and Seller. 10/12

## **SERVICE & IMPORTANT NOTICE**

The manufacturer has a policy of continuous improvement on its products and reserves the right to change materials and specifications without notice.

### **WARNING**

**Please do not place the unit within reach of children.  
For adult use only.**

Contact **info@vinotemp.com** with any questions or visit:  
**www.vinotemp.com**



17621 S. Susana Road  
Rancho Dominguez, CA 90221

Vinotemp is a registered trademark of Vinotemp International. All products, features, and services are subject to change without notice. We cannot guarantee the accuracy of the contents of this document. We disclaim liability for errors, omissions, or future changes.

© 2012 Vinotemp International. All rights reserved.