

Vinotemp®

A PROUD HERITAGE OF EXPERIENCE & QUALITY

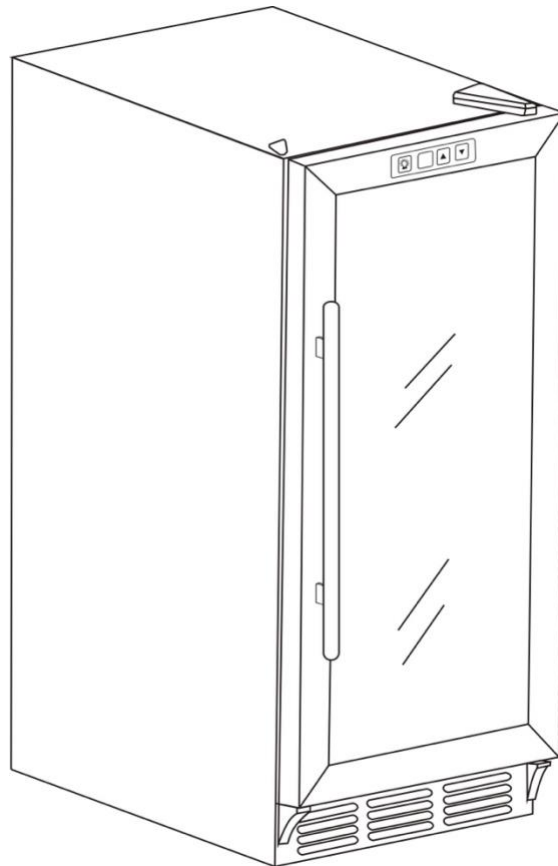

BEVERAGE COOLER

VT-BC32SB10

OWNER'S MANUAL

WWW.VINOTEMP.COM

YOUR BEVERAGE COOLER

This unit can be used for storage and/or service. The unit has a glass door and soft interior light that you can leave on to elegantly display your beverage.

General Operating Instructions

Remove all external and internal packaging from your beverage cooler. Be sure that all parts have been included before discarding any packaging materials. You may want to keep the box and packing materials for use at a later date.

Upon receipt and inspection of unit, the power cord must be replaced if it is damaged. Contact our customer service at 1-800-777-8466 or info@vinotemp.com.

- Let the unit rest UNPLUGGED for 24 hours once you have it placed in your home.
- Please fully read the instruction manual.
- Save these instructions.

**Please read and follow all safety rules
and operating instructions before using.**

**To register your product, visit:
<http://www.vinotemp.com/Warranty.aspx>
Register your warranty within 10 days of receiving the unit.
Please be sure to retain your proof of purchase.**

Table of Contents

PARTS AND SPECIFICATIONS.....	4
IMPORTANT SAFETY INSTRUCTIONS	5
CORD INSTRUCTIONS.....	5
BEVERAGE COOLER INSTALLATION.....	6
OPERATING INSTRUCTIONS.....	6
TEMPERATURE CONTROL.....	7
CLEANING AND CARE.....	7
MOVING YOUR BEVERAGE COOLER.....	7
TROUBLESHOOTING GUIDE	8
TERMS AND CONDITIONS.....	9
SERVICE & IMPORTANT NOTICE	10

PARTS AND SPECIFICATIONS

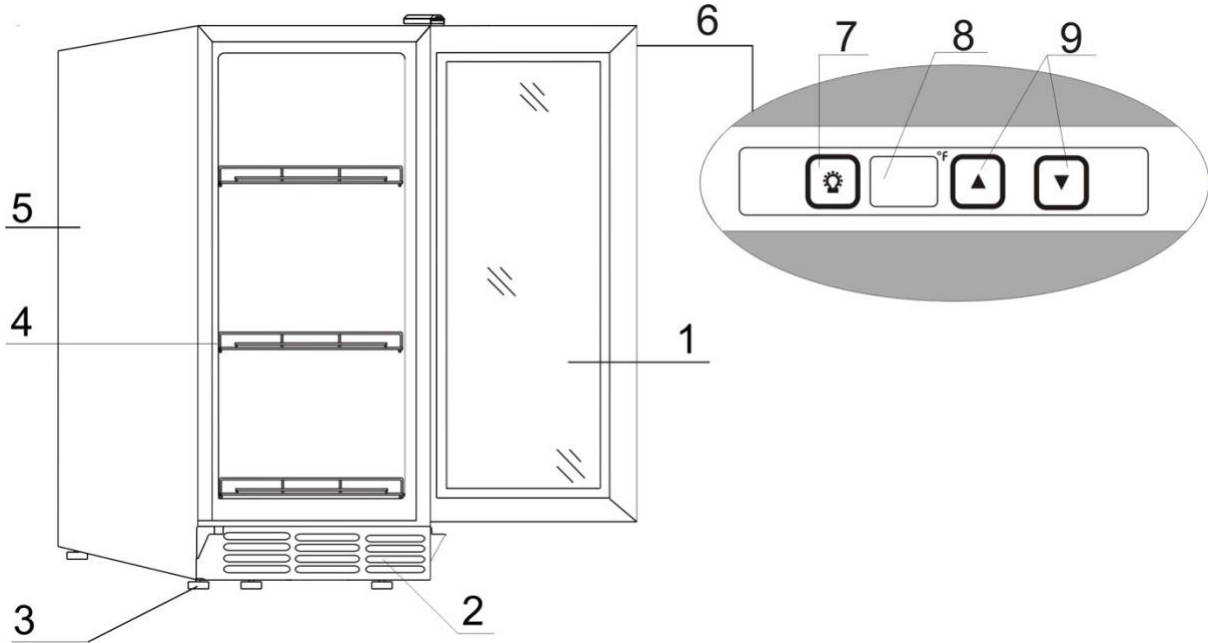

1. Glass Door
2. Grill
3. Adjustable Leveling Legs
4. Shelf
5. Cabinet
6. Control Panel
7. Light Switch
8. LED Temperature Indicator
9. Temperature Adjustment Button

Item Number	VT-BC32SB10
Dimension (WxDxH) without handle	15"x21 3/4"x34 1/2"
Weight	74 Lbs
Power Consumption	1.8 kW.h/24h
Cooling System	R134a
Ambient Temp. Range	60~90°F
Temperature Range	40~65°F
Rated Voltage	115V
Rated Frequency	60Hz
Input Power	120W

*Note: This wine cooler is designed to store standard Bordeaux 750 ml bottles. Storing large and/or oddly shaped bottles (including champagne and sparkling wine bottles) will decrease the capacity of your wine cooler.

IMPORTANT SAFETY INSTRUCTIONS

When using an electrical appliance, basic precautions should be followed to reduce the risk of fire, electric shock, and personal injury.

- Use this appliance only as described in this manual. Other uses are not recommended and may cause fire, electric shock or injury.
- This product is intended for indoor, household use only.
- To protect against electric shock, do not immerse unit, plug or cord in water or other liquids. Avoid locating the unit in moist areas.
- Never allow children to operate, play with, or crawl inside the unit.
- Unplug from the outlet when not in use, when moving from one location to another, or before cleaning.
- To disconnect the appliance, grip the plug and pull it from the wall outlet. Never pull by the cord.
- Do not operate the appliance in the presence of explosive and/or flammable fumes.
- Do not place the appliance or any of its parts near an open flame, cooking or other heating appliance.
- Do not operate the appliance with a damaged cord or plug. If the product malfunctions, or if it is dropped or damaged in any manner, do not use.
- The use of attachments is not recommended and may be hazardous.
- Do not operate if the housing is removed or damaged.
- A loose fit plug may cause overheating and a distortion of the plug. Contact a qualified electrician to replace loose or worn outlet.
- This appliance is designed to be built-in (fully recessed) or free standing.
- The beverage cooler is intended for use in a controlled ambient location such that the ambient temperature does not exceed 90°F (32°C).
- Locate the unit away from direct sunlight and sources of heat (stove, heater, radiator, etc.). Direct sunlight may affect/alter the outside color of the appliance.

WARNING: To reduce the risk of fire, electric shock or personal injury, unplug or disconnect the appliance from the power supply before servicing.

WARNING: Risk of child entrapment. Before you throw away your old beverage cooler, take off the door and leave the shelves in place so that children may not easily climb inside.

CORD INSTRUCTIONS

For your protection, this unit should be properly grounded. Unit is equipped with a 3-conductor cord set that has a molded 3-prong grounding-type plug, and should be used in combination with a properly connected grounding-type outlet as shown in figure A.

It is not recommended to use this beverage cooler with an extension cord or power board. Please ensure that the appliance is plugged directly into the electrical outlet.

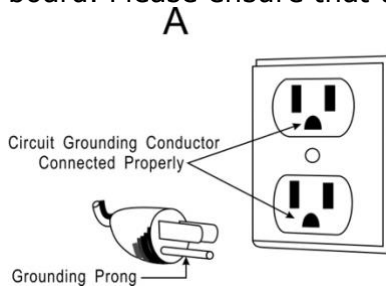

BEVERAGE COOLER INSTALLATION

- Remove the exterior and interior packaging before use.
- Check to be sure you have all of the parts and 1 owner's manual.
- Place your beverage cooler on a flat, dry surface that is strong enough to support the unit when fully loaded.
- This unit is designed to be built-in (fully recessed) or free standing.
- Do not place heavy objects on top of the unit.
- Unit is not designed for installation in a garage, basement, or any other location where a controlled ambient environment between 60° and 90°F cannot be maintained.
- For freestanding installation, 6" of space at the back, 10-12" of space on each side, and unlimited clearance at the top of the wine cooler are suggested to ensure proper air circulation to cool the compressor and condenser. Do not place underneath a table, counter top, or anything of the sort as this will not allow for proper air circulation.
- Do not place the unit in direct sunlight or near sources of heat. Extreme hot and cold ambient temperatures may cause the unit not to perform properly or increase electrical consumption.
- Do not place the unit next to a major appliance that emits large amounts of heat, such as a dishwasher, microwave, oven, etc.
- Do not plug unit into the same outlet as a refrigerator or microwave.
- Before connecting the appliance to the power source, let it stand upright for approximately 24 hours. This will reduce the possibility of a malfunction in the cooling system from handling during transportation.
- Clean the interior surface with lukewarm water using a soft cloth before first use.

OPERATING INSTRUCTIONS

1. Gently place/slide the racks into the beverage cooler.
2. Determine the best temperature setting to use.
3. Place bottles/cans inside the cooler.
4. Plug the power cord into a standard grounded electrical outlet.
5. Limit the frequency of opening the door to conserve energy and maintain proper storage temperature.
6. You can turn the interior light on and off by touching the button labeled with a light on the control panel.

IMPORTANT: When using the beverage cooler for the first time, allow at least 24 hours for the internal temperature to adjust properly. Make sure there are at least 3 to 5 bottles in the unit.

TEMPERATURE CONTROL

IMPORTANT: In order to operate efficiently, this product should be in an environment with an ambient temperature of less than 90°F (32°C).

Temperature preset:

For your convenience, the manufacturer has pre-set the temperature of the unit at 48°F (9°C).

Setting the temperature:

You can manually adjust the temperature. Simply press the "▼" button on the control panel to decrease the temperature and the "▲" button to increase the temperature by 1 degree increments inside the beverage cooler. The temperature range for this unit is from 40°F (4°C) to 65°F (18°C).

When the cabinet temperature is too low, the LED will display "LL". When the temperature is too high, it will display "HH". The "ER" display shows when there has been a power disruption.

CLEANING AND CARE

- Always unplug the beverage cooler before cleaning.
- Do not use benzene, scrubbing brushes or chemical cleaners as these will damage the unit.
- Use only a mild, nonabrasive cleanser to clean the exterior of the cabinet.
- Clean the stainless steel door and handle by wiping with a warm water and baking soda solution. The solution should be about 2 tablespoons of baking soda to a quart of water.
- Wash the racks with a mild detergent solution.
- Always dry all parts with a clean dry cloth before plugging the beverage cooler back into the receptacle.

MOVING YOUR BEVERAGE COOLER

- Always unplug the beverage cooler before moving.
- Always remove all beverages before moving the beverage cooler.
- Securely tape down all loose items (shelves) inside your appliance.
- Turn the leveling legs up to the base to avoid damage.
- Tape the door shut.
- Be sure the beverage cooler stays in the upright position during transportation
- Protect the outside of appliance with a blanket or similar item when moving as needed.

TROUBLESHOOTING GUIDE

You can solve many common beverage cooler problems easily, saving you the cost of a possible service call. Try the suggestion below to see if you can solve the problem before contacting Vinotemp at info@vinotemp.com.

PROBLEM	POSSIBLE CAUSE
Door will not close properly.	<ul style="list-style-type: none"> • The beverage cooler is not level. • The shelves are out of position. • The door was reversed and not properly installed. • The door gasket is dirty.
Unit does not operate—does not have power	<ul style="list-style-type: none"> • Check that unit is plugged into the wall socket. • Make sure the wall socket has power. If outlet is controlled by a wall switch, make sure switch is set to on. Test wall socket functionality by testing another electrical appliance in the power socket.
Power is ON but the unit will not cool.	<ul style="list-style-type: none"> • Make sure there are at least 3 to 5 bottles in the unit. When using the unit for the first time, it can take up to 24 hours to reach the desired temperature. • If the room temperature is above 90°F (32°C), the unit will not get below 51°F (11°C). Humidity does not affect the cooling ability of the unit. • To achieve accurate temperature control, the unit should not be used or operated in any of the following locations: <ul style="list-style-type: none"> ○ In a sunny place ○ In a room with poor air circulation such as a garage near another heat-producing appliance such as a dishwasher, oven or refrigerator. ○ With an outlet shared with a refrigerator, as the refrigerator will drain power from the beverage cooler. ○ In a cabinet or closet. • Make sure the cooling vents are not obstructed.
Fan is always running.	<ul style="list-style-type: none"> • This is simply a function of the cooling system. The lower the setting, the more the fan will run. If the room is warmer than 90°F (32°C), it will run more. • The unit has been designed to run continuously when operating at the lower temperatures.
Vibrations	<ul style="list-style-type: none"> • Check to make sure the beverage cooler is level.

TERMS AND CONDITIONS

Vinotemp International ("Seller") and the person or entity that acquires these goods from Seller ("Purchaser") hereby fully agree to the following terms and conditions of the sale: Shipping fees are the responsibility of the Purchaser whether freight prepaid or freight collect. Seller assumes no responsibility for the goods sold to the Purchaser once the goods have left the Seller's premises, including, but not limited to, late delivery by the moving carrier, or for events caused by any difficulty carrier incurs in attempting to fit the goods into the Purchaser's place of business or residence due to the size of the goods or otherwise. Purchaser assumes all responsibility for delivery, payment of freight, access, measurement, installation, hook-up, wiring, moving and storage of the goods. The transportation of all goods is subject to the terms and conditions which the moving carrier imposes on Purchaser including, but not limited to, additional charges imposed per flight of stairs, and/or additional charges resulting from the carrier's inability to safely and/or adequately use the building elevator to lift the goods to an upper floor. Any claim for damages incurred during shipment by the carrier of the goods are insured and handled directly with the carrier and must be noted at time of delivery. Any damages due to manufacture defects will be handled directly with Vinotemp International, subject to the limited warranty.

All sales are final, and unless authorized in writing by the Seller, Purchaser may not return the goods, under any circumstance. If Purchaser refuses to accept the goods, under any circumstance, the Purchaser is liable for the return and cost of freight both ways, and if Seller does take back the goods, there will be a restocking/service fee that is 35% of the purchase price of the goods. (Product must be in original packaging). Built-to-Order products (including Cabinets, Racking, and Accessories) are non-returnable. Purchaser must notify Seller of non-conforming goods within four days of delivery, after which time all goods are deemed accepted. If an order has been placed and production has started, cancellation of your order will be a 15% charge. If Purchaser tenders payment with a check that has insufficient funds (NSF), or stops payment on a check or credit card for any reason, Purchaser agrees to pay for all costs associated with the Seller's collection or litigation of such a claim, including without limitation extra damages, court costs and attorneys' fees. Finance charges begin the date of invoice. Collection fees plus NSF fee of \$50 will be added to your invoice, which you agree to promptly pay. Title to the goods does not pass until payment is received in full by Seller and Seller retains a security interest in the goods until they are paid for in full. Statute of limitations must be handled in arbitration in the County of Los Angeles.

LIMITED WARRANTY: Seller warrants that the goods will be free of defects in materials and workmanship as follows: Furniture style (wood) wine cabinets made in the U.S.: all cooling unit parts for a period of 5 (five) years; cabinetry and labor (uninstalled) for a period of 12 (twelve) months from date of sale. For the metal cabinet wine units: parts and labor for cooling system and cabinetry for a period of 12 (twelve) months from date of sale. Thermoelectric Units: 90 (ninety) days from the date of sale (including Wine Coolers, Beer Dispensers, Humidor, Portofino Wood Cellars, and Refrigerators). Wine-Mate Split Systems and installed products are parts only for 1 year, no labor. Other Wine-Mate Cooling Systems are 5 years parts, 1 year labor. Wine Accessories and Racking Systems are not warranted. There is no warranty on parts purchased separately. Removal and re-installation of unit is not included in warranted labor. Purchaser's exclusive remedy is limited, at Seller's option; to repair or replace defective part[s] with either new or factory reconditioned part[s]. Purchaser is responsible for shipping the unit pre-paid to designated facility and Seller will pay return shipping charges in the continental United States for items repaired under warranty within 12 (twelve) months from date of sale. Since the natural variation in texture, density, grain, color, tone and shade of wood is unavoidable; Seller does not guarantee the texture, color, tone or shade of the wood: nor does seller guarantee the colorfastness of wood or against peeling, chipping, cracking or scratching. Note: Unfinished wood is subject to warping; all wood surfaces must be sealed before placing cellar into service. Improper placement of the unit will void the warranty. By Vinotemp in writing, any third party repair facility must be pre-approved before providing parts free of charge. This limited warranty does not cover damage due to such things as accident, misuse, abuse, mishandling, neglect, acts of God, fires, earthquakes, floods, high winds, government, war, riot or labor trouble, strikes, lockouts, delay of carrier, unauthorized repair, or any other cause beyond the control of the Seller, whether similar or dissimilar to the foregoing. Seller is not responsible for any damages caused to Purchaser's property resulting from the good. This limited warranty applies only inside the Continental US (Alaska, Puerto Rico and Hawaii are not warranted.).

For Non-New Units (Scratch & Dent/Refurbished/Floor Models), warranty for compressor units is 90 days from your dated invoice and 30 days for thermoelectric units (parts for function only, not cosmetic defects). These units are refurbished and sold as is; Purchaser assumes risks to the quality and performance of goods and assumes the costs of all necessary service or repair not covered herein.

For Element Grills (via Element Products LLC), grills have a 1 year comprehensive parts warranty on entire product. Three years limited parts warranty covering the stainless burner and a thirty day limited parts warranty on grill accessories. If grill is defective and unused plus all packaging and parts are intact, we will either replace the grill or provide service to repair the grill. Returned product must accompany all original packaging and parts and is subject to our 35% restocking fee (and freight both ways).

With Wine-Mate products, if the customer calls and the product is "defective", you must obtain a letter from your qualified refrigeration technician at the customers cost, to verify that the unit was installed properly, with proper ventilation and the unit is truly malfunctioning due to manufacture defect.

Purchaser understands and acknowledges that the goods sold here are wine cellars, cigar humidors, and/or other similar units which house wine or cigars. Purchaser assumes all risk of using these units, including risk of spoilage, humidity variations, temperature variations, leaks, fire, water damage, mold, mildew, dryness and similar and any other perils that might occur.

Seller is not responsible for incidental or consequential damages, and there are no warranties, expressed or implied, which extend beyond the Limited Warranty described above. Warranty and liability are non-transferable. The implied warranties of merchantability and of fitness for a particular purpose are hereby expressly disclaimed. Some states do not allow the exclusion of incidental or consequential damages, or a waiver of the implied warranties of fitness and/or merchantability, so the above limitations may not apply to you. This warranty gives you specific legal rights and you may also have other rights which vary from state to state. Seller disclaims any indemnification for claims of infringement of any intellectual property of protectable nature. In the event of any dispute between Seller and Purchaser arising out of or relating to these terms and conditions or to the goods sold generally, Purchaser must first file a written claim with Seller within ten days of the occurrence giving rise to the claim and wait an additional thirty days for a response before initiating any legal action. The sale and all terms are subject to California law. Any legal proceeding arising out of or relating to these terms and conditions or to the goods sold generally shall be brought solely and exclusively in the County of Los Angeles. In no event may Purchaser initiate any legal proceeding more than six months after the occurrence of the event giving rise to the dispute.

The above terms and conditions are the only ones governing this transaction and Seller makes no oral representations of any kind. These Terms and Conditions can only be modified in writing, signed by both Purchaser and Seller. 10/12

SERVICE & IMPORTANT NOTICE

Upon receipt and inspection of unit, the supply cord must be replaced if it is damaged. Contact our customer service at 1-800-777-8466 or info@vinotemp.com.

The manufacturer has a policy of continuous improvement on its products and reserves the right to change materials and specifications without notice.

WARNING:

**Please do not place the unit within reach of children.
For adult use only.**

Contact **info@vinotemp.com** with any questions or visit:

www.vinotemp.com

17621 S. Susana Road
Rancho Dominguez, CA 90221
www.vinotemp.com

Vinotemp is a registered trademark of Vinotemp International. All products, features, and services are subject to change without notice. We cannot guarantee the accuracy of the contents of this document. We disclaim liability for errors, omissions, or future changes.

© 2012 Vinotemp International. All rights reserved.