

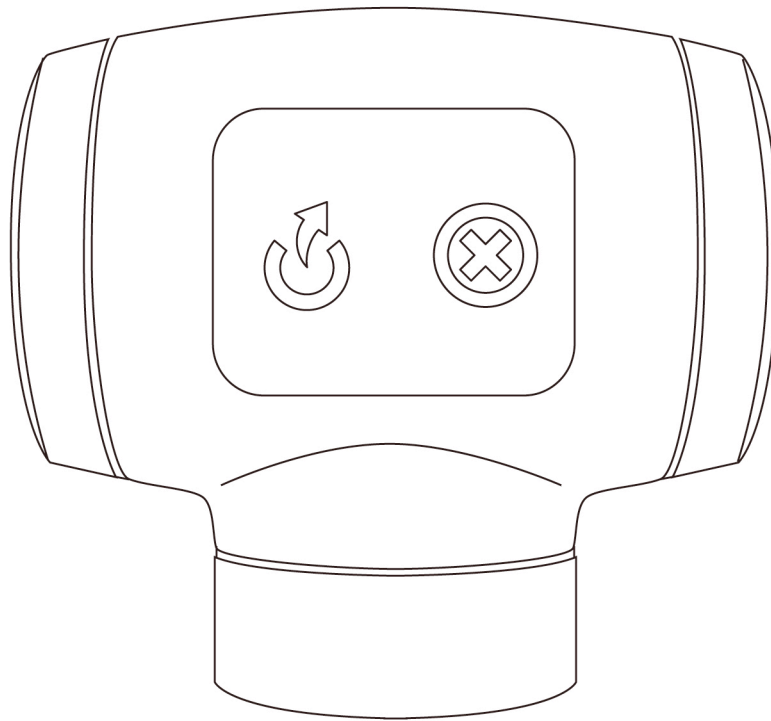

# Automatic Wine Preserver



EP-VACSEAL4

**OWNER'S MANUAL**



The Epicureanist Automatic Wine Preserver is designed to fit most wine bottles to vacuum seal and to provide effective wine preservation. It is the perfect combination of function and style, helping to keep your wine tasting as good as when you first open it.

**PLEASE READ ALL INSTRUCTIONS BEFORE USE  
-SAVE INSTRUCTIONS-**

## **IMPORTANT SAFETY AND USAGE INSTRUCTIONS**

- Exercise caution and use reasonable supervision when device is used near children. Never allow children to operate or play with unit.
- Intended for indoor household use only.
- Do not use this device for anything other than its intended purpose.
- Locate the unit away from direct flames and other sources of heat (stove, heater, radiator, etc.)
- Do not immerse in water or other liquids. Avoid locating the unit in moist areas.

**WARNING:** Do not use the unit as a handle to lift or move the bottle. This may cause the bottle to fall out of the appliance.

# OVERVIEW OF PARTS

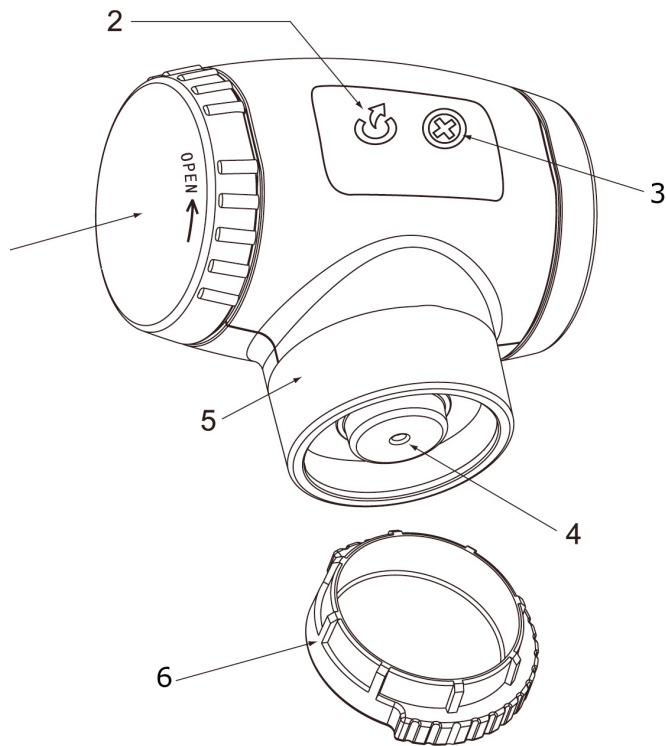

1. Side Battery Cover
2. Vacuum Indicator
3. Error/Low Power Indicator
4. Bottle Seal
5. Main Unit
6. Protective cover

## SPECIFICATIONS

Fits bottle sizes: Standard 750ml bottles

Fits bottle mouth size: .69in. - .77in (17.5mm – 19.5mm)

## ADDING/REPLACING BATTERIES

- Unit requires 2 AAA batteries (not included).
- Upon first use, batteries must be inserted into device. Turn the battery cover counter clockwise to remove the cover and insert batteries. Observe the correct polarity indicated in the battery compartment. Close the battery cover by turning it clockwise.
- When the capacity of the batteries is low, the Low Power Indicator will light up. Follow the steps indicated above to replace the batteries.

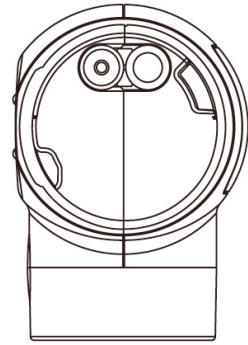

## BATTERY PRECAUTIONS

- Dispose of used batteries properly. Do not dispose of them in a fire.
- Do not leave the batteries where a child or pet could play with or swallow them. If batteries are ingested, contact a physician immediately.
- A mishandled battery may explode. Do not attempt to recharge or disassemble the alkaline batteries.
- Only use 2 new AAA alkaline batteries. Do not mix old and new batteries, different types of batteries, or use rechargeable batteries in the battery compartment.

## SEALING THE WINE BOTTLE

- Remove the Protective Cover from the bottom of the wine preserver.
- Position the unit over an upright wine bottle and push down gently, but firmly.
- The battery-operated preserver automatically removes air from the bottle when a proper seal has been achieved.
- The Vacuum Indicator light will blink while the unit is removing the air from the bottle.
- The unit will automatically shut off when it has finished removing all the air from the bottle. The Vacuum Indicator light will light up for 60 seconds, and then shut off.



## OPERATING NOTES

- The preserver will automatically shut off if it is being used on a wine bottle that is tilted 45 degrees or more.
- The unit will shut off if it has attempted to remove air from a wine bottle for more than 5 minutes. The Error Indicator light will blink indicating that there may be a malfunction with the unit, which may need to be repaired.
- The wine preserver may not turn on if the battery power is too low, if the preserver is not correctly placed on the wine bottle, or if there is no wine in the bottle.
- Allow approximately 60 seconds for the Preserver to completely pressurize the bottle.

# REMOVING THE WINE PRESERVER

Pull up on the wine preserver to remove it from the bottle.

# CARE AND MAINTENANCE

Clean the wine preserver with a damp, soft, clean cloth. Do not submerge the wine preserver in water.

# TROUBLESHOOTING

PROBLEM	SOLUTION
The wine preserver does not turn on	<ul style="list-style-type: none"><li>• Make sure the bottle is placed on a flat surface.</li><li>• The wine preserver will automatically shut off if the wine bottle is tipped more than 45 degrees.</li><li>• The wine preserver has not created a proper seal.</li><li>• Re-insert the wine preserver into the wine bottle.</li><li>• The batteries may be low on power. Replace the batteries.</li></ul>
The Error Indicator Light is blinking	<ul style="list-style-type: none"><li>• The batteries are low on power. Replace the batteries.</li></ul>
The Error Indicator Light is on and the wine preserver will not turn on	<ul style="list-style-type: none"><li>• A proper seal has not been achieved. Re-position the wine preserver on the bottle, ensure it is inserted properly.</li></ul>

# IMPORTANT DISPOSAL INSTRUCTIONS

As a responsible company, we care about the environment. As such, we urge you to follow the correct disposal procedures for your product, batteries, and packaging materials. This will help conserve all natural resources and ensure that it is recycled in a manner that protects the environment.

You must dispose of this product and its packaging according to local laws and regulations. Because this product contains electronic components and batteries, the product and its accessories must be disposed of separately from household waste when the product reaches the end of its life cycle.

The product and batteries should be taken to a proper recycling/disposal facility.

# TERMS OF SALE & WARRANTY

Epicureanist LLC ("Seller") and the person or entity that acquires these goods from Seller ("Purchaser") hereby fully agree to the following terms and conditions of the sale: Shipping fees are the responsibility of the Purchaser whether freight prepaid or freight collect. Seller assumes no responsibility for the goods sold to the Purchaser once the goods have left the Seller's premises, including, but not limited to, late delivery by the moving carrier, or for events caused by any difficulty carrier incurs in attempting to fit the goods into the Purchaser's place of business or residence due to the size of the goods or otherwise. Purchaser assumes all responsibility for delivery, payment of freight, access, measurement, installation, hook-up, wiring, moving and storage of the goods. The transportation of all goods is subject to the terms and conditions which the moving carrier imposes on Purchaser including, but not limited to, additional charges imposed per flight of stairs, and/or additional charges resulting from the carrier's inability to safely and/or adequately use the building elevator to lift the goods to an upper floor. Any claim for damages incurred during shipment by the carrier of the goods are insured and handled directly with the carrier and must be noted at time of delivery. Any damages due to manufacture defects will be handled directly with Epicureanist, subject to the limited warranty.

All sales are final, and unless authorized in writing by the Seller, Purchaser may not return the goods, under any circumstance. If Purchaser refuses to accept the goods, under any circumstance, the Purchaser is liable for the return and cost of freight both ways, and if Seller does take back the goods, there will be a restocking/service fee that is 35% of the purchase price of the goods. Built-to-Order products (including Cabinets, Racking, and Accessories) are non-returnable. Purchaser must notify Seller of non-conforming goods within four days of delivery, after which time all goods are deemed accepted. If an order has been placed and production has started, cancellation of your order will be a 15% charge.

If Purchaser tenders payment with a check that has insufficient funds (NSF), or stops payment on a check or credit card for any reason, Purchaser agrees to pay for all costs associated with the Seller's connection or litigation of such a claim, including without limitation extra damages, court costs and attorneys' fees. Finance charges begin the date of invoice. Collection fees plus NSF fee of \$50 will be added to your invoice, which you agree to promptly pay. Title to the goods does not pass until payment is received in full by Seller and Seller retains a security interest in the goods until they are paid for in full.

**LIMITED WARRANTY:** Seller warrants that the goods will be free of defects in materials and workmanship as follows: Furniture style (wood) wine units: all cooling unit parts for a period of 5 (five) years; cabinetry and labor (uninstalled) for a period of 12 (twelve) months from date of sale. For the metal cabinet wine units: parts and labor for cooling system and cabinetry for a period of 12 (twelve) months from date of sale. Thermoelectric Units: 90 (ninety) days from the date of sale. (This includes Wine Coolers, Beer Dispensers, Humidor, Portofino Wood Cellars, and Refrigerators). Wine-Mate Split Systems and installed products are parts only for 1 year, no labor. Other Wine-Mate Cooling Systems are 5 years parts, 1 year labor. Element Grills (via Element Products LLC) have a 1-year comprehensive parts warranty on entire product. Three years limited parts warranty covering the stainless burner and a thirty day limited parts warranty on grill accessories. Wine Accessories and Racking Systems are not warranted. For a scratch and dent/refurbished unit, warranty is 3 months from your dated invoice (parts for function only, not cosmetic). There is no warranty on parts purchased separately. Removal and re-installation of unit is not included in warranted labor. Purchaser's exclusive remedy is limited, at Seller's option; to repair or replace defective part[s] with either new or factory reconditioned part[s]. Purchaser is responsible for shipping the unit pre-paid to designated facility and Seller will pay return shipping charges in the continental United States for items repaired under warranty within 12 (twelve) months from date of sale. Since the natural variation in texture, density, grain, color, tone and shade of wood is unavoidable; Seller does not guarantee the texture, color, tone or shade of the wood: nor does seller guarantee the colorfastness of wood or against peeling, chipping, cracking or scratching. Note: Unfinished wood is subject to warping; all wood surfaces must be sealed before placing cellar into service. Improper placement of the unit will void the warranty. This limited warranty does not cover damage due to such things as accident, misuse, abuse, mishandling, neglect, acts of God, fires, earthquakes, floods, high winds, government, war, riot or labor trouble, strikes, lockouts, delay of carrier, unauthorized repair, or any other cause beyond the control of the Seller, whether similar or dissimilar to the foregoing. Seller is not responsible for any damages caused to Seller's property resulting from the good. This limited warranty applies only inside the Continental US. (Alaska, Puerto Rico and Hawaii are not warranted.)

For Element/Fuego Grills, warranty is 1 year, with 3 years on the burner. If grill is defective and unused plus all packaging and parts are intact, we will either replace the grill or provide service to repair the grill. Returned product must accompany all original packaging and parts and is subject to our 35% restocking fee (and freight both ways).

With Wine-Mate products, if the customer calls and the product is "defective", you must obtain a letter from your qualified refrigeration technician at the customer's cost, to verify that the unit was installed properly, with proper ventilation and the unit is truly malfunctioning due to manufacture defect.

Purchaser understands and acknowledges that the goods sold here are wine cellars, cigar humidors, and/or other similar units which house wine or cigars. Purchaser assumes all risk of using these units, including risk of spoilage, humidity variations, temperature variations, leaks, fire, water damage, mold, mildew, dryness and similar and any other perils that might occur.

Seller is not responsible for incidental or consequential damages, and there are no warranties, expressed or implied, which extend beyond the Limited Warranty described above. Warranty and liability are non-transferable. The implied warranties of merchantability and of fitness for a particular purpose are hereby expressly disclaimed. Some states do not allow the exclusion of incidental or consequential damages, or a waiver of the implied warranties of fitness and/or merchantability, so the above limitations may not apply to you. This warranty gives you specific legal rights and you may also have other rights which vary from state to state. Seller disclaims any indemnification for claims of infringement of any intellectual property of protectable nature.

In the event of any dispute between Seller and Purchaser arising out of or relating to these terms and conditions or to the goods sold generally, Purchaser must first file a written claim with Seller within ten days of the occurrence giving rise to the claim and wait an additional thirty days for a response before initiating any legal action. The sale and all terms are subject to California law. Any legal proceeding arising out of or relating to these terms and conditions or to the goods sold generally shall be brought solely and exclusively in the County of Los Angeles. In no event may Purchaser initiate any legal proceeding more than six months after the occurrence of the event giving rise to the dispute.

The above terms and conditions are the only ones governing this transaction and Seller makes no oral representations of any kind. These Terms and Conditions can only be modified in writing, signed by both Purchaser and Seller. 10/12

## SERVICE & IMPORTANT NOTICE

The manufacturer has a policy of continuous improvement on its products and reserves the right to change materials and specifications without notice.

Contact [info@epicureanist.com](mailto:info@epicureanist.com) with any questions or visit [www.epicureanist.com](http://www.epicureanist.com)



17621 S. Susana Road  
Rancho Dominguez, CA 90221  
[www.epicureanist.com](http://www.epicureanist.com)

### **WARNING:**

**Please do not place the unit within reach of children.  
For adult use only.**

Epicureanist is a trademark of Epicureanist LLC. All products, features, and services are subject to change without notice. We cannot guarantee the accuracy of the contents of this document. We disclaim liability for errors, omissions, or future changes.

©2012 Epicureanist LLC. All rights reserved.